

**It's Cool:**  
***The Shape of Change***

The text of  
Lesson 4: It's Cool  
From the books

***The Shape of Change***  
and  
***The Shape of Change: Stocks and Flows***

By Rob Quaden and Alan Ticotsky  
With Debra Lyneis  
Illustrated by Nathan Walker  
Published by the Creative Learning Exchange  
©May 2004 -2006

Prepared with the Support of  
**The Gordon Stanley Brown Fund**

Based on work supported by  
**The Waters Foundation**

***The Shape of Change***

Presenting eleven attractively illustrated and  
formatted classroom activities.

Available from  
*The Creative Learning Exchange*  
Acton, Massachusetts  
(978) 635-9797

<http://www.clexchange.org>

[milleras@clexchange.org](mailto:milleras@clexchange.org)

## Introduction

In this lesson, students engage in the scientific method as they measure, record, and graph the changing temperature of a cooling cup of boiling water. They look for patterns of behavior over time and form hypotheses. The lesson reinforces science concepts including energy transfer, the Centigrade scale, laboratory technique and measurement skills. Math skills and concepts include measuring, gathering data, making graphs, and working with rates of change. <sup>1</sup>

## Materials

- Electric tea kettle to boil water in the classroom
- A stopwatch or clock/watch with a minute hand or timer.
- A cup for hot liquids and a lab thermometer for each team of students
- Copies of three worksheets for each student:
  1. *Cooling Prediction Graph* (page 9)
  2. *Cooling Data Table* (page 10)
  3. *Cooling Experiment Graph* (page 11)

## How It Works

There is a difference between heat and temperature. Heat is a form of energy which makes molecules in water move around very rapidly. When water is heated in the kettle, it gains more heat energy. When the water cools, energy flows out of the water and into the air.

Temperature is one *measure* of how much heat energy an object has, and it is measured on a thermometer in degrees. Heat is the amount of energy needed to bring the water to a certain temperature. Two different objects can have the same temperature but contain different amounts of heat energy. Two different amounts of water at the same temperature hold different amounts of heat energy. Various items baked in an oven together contain different amounts of heat energy. Heat energy is measured in calories or BTUs. Heat energy always travels from a region with higher temperature to a region with lower temperature.

In the classroom experiment, heat from the boiling water flows into the air, the water cools, and the temperature drops. The temperature drops rapidly at first, but the rate of change slows as the water approaches room temperature.

## Procedure

1. Explain to students that they will be conducting a scientific experiment. They will be measuring the temperature of hot water as it cools and they will record and graph their data.

2. Emphasize that the experiment will only work if students follow the guidelines.
  - Boiling water is very hot and dangerous, so they must be very careful with it.
  - They must record their data very accurately.
  - They must cooperate in teams in order to accomplish this task.

**Safety First!!!**

Make sure to use thermometers and cups that are designed for hot liquids. Standard air temperature thermometers may burst in hot water.

3. To familiarize students a feel with the Celsius scale, discuss some of the following measures:

100 degrees: water boils  
40 degrees: fever  
37 degrees: normal body temperature  
30 degrees: a warm summer day  
20 degrees: room temperature  
0 degrees: water freezes

4. Draw a set of axes on the board. Label the horizontal axis "Time (Minutes)." Label the vertical axis "Temperature (Degrees Celsius)," with a minimum value of 0 degrees Celsius and a maximum value of 100 degrees Celsius.

Choose students to come to the board to draw *behavior over time graphs* the following:  
(A *behavior over time graph* is a line graph sketching how something changes over time.)

- The temperature of water in a pot on the stove starts at 50 degrees and rises at a constant rate to 90 degrees.

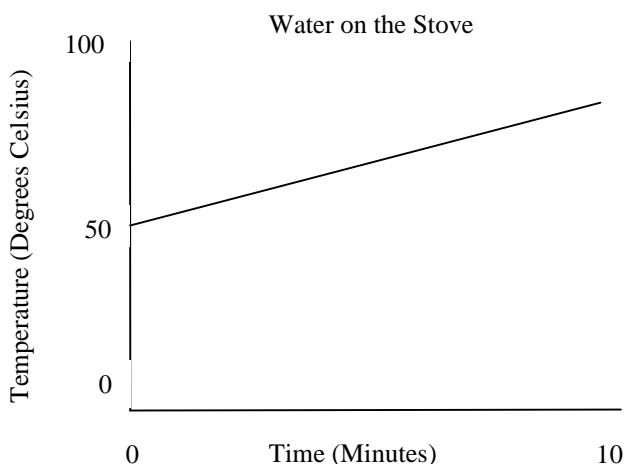

- The temperature in a room is 20 degrees and does not change.

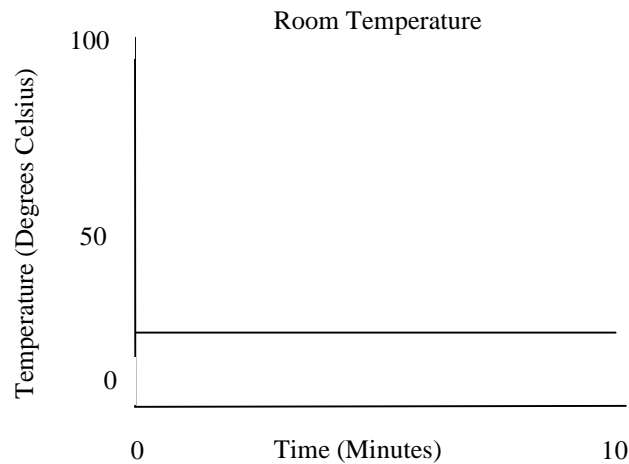

5. Ask students to think about what will happen to the temperature of boiling water in a cup over time. Ask them to sketch a *behavior over time graph* of their predictions on the *Cooling Prediction Graph* worksheet (page 9).

### Predictions

A prediction is what students think will happen -- it does not matter if it is wrong or right. Making predictions helps students think about the experiment when they see how closely the results match their predictions.

6. Give each team one cup and fill it with boiling water. Have students measure the initial temperature immediately and record it on the *Cooling Data Table* worksheet (page 10). Note that the initial temperature is less than 100 degrees because the heat source has been removed.

7. Using the stopwatch, announce each subsequent minute with a ten second warning and tell the students to “measure and record” their water temperature.

- Make sure that more than one student reads the thermometer. This increases the learning and the accuracy of the measurements.
- While teams gather and check their data, each individual student completes his or her own data chart and graphs.

8. After about five minutes, when all teams are on track, help students plot their data on the *Cooling Experiment Graph* worksheet (page 11).

- Plot the first few points together, checking that students mark the initial temperature on the vertical axis and a dot on each subsequent minute line.
- This can be confusing for young students. Suggest that students use a straightedge to follow each minute line accurately up from the bottom to where it intersects the current temperature line.

Meanwhile, continue to announce each minute with instructions to “measure and record.” Continue graphing for at least twenty minutes.

7. Finally, ask students to connect the dots on their graphs. This should be a *smooth curved line*, so it is best if students do this without using a straight edge.

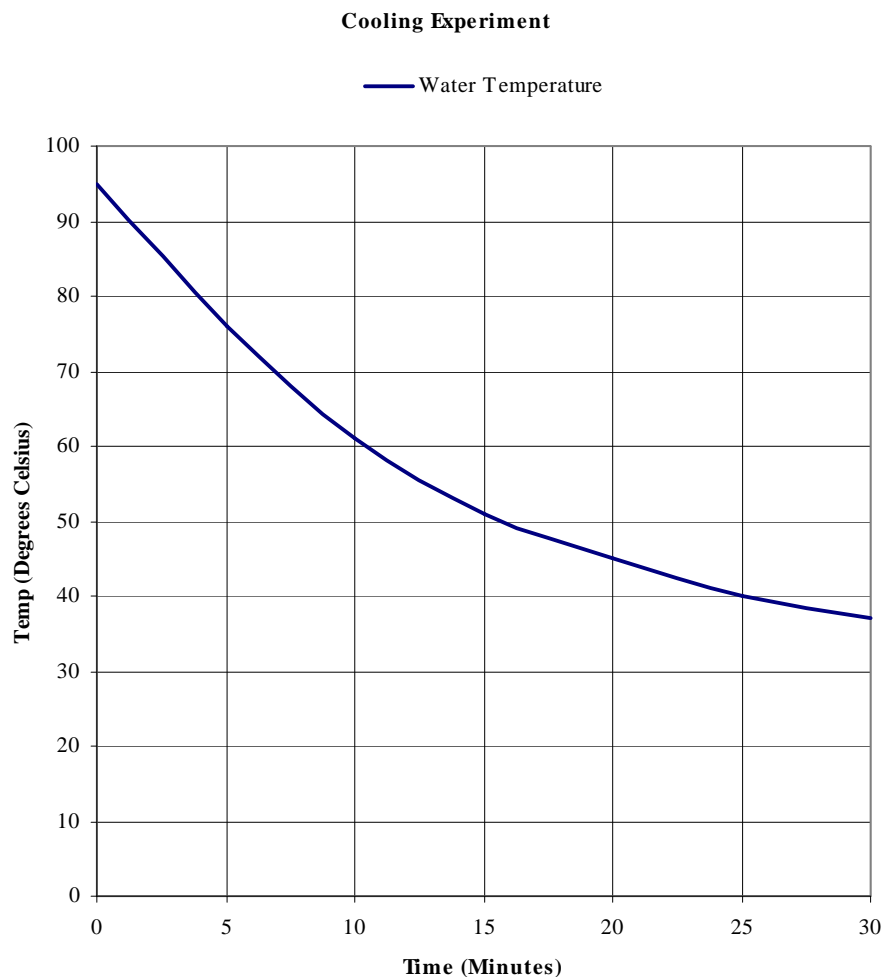

## Bringing the Lesson Home

Students have made predictions and conducted an experiment. Now, to come full circle, they make sense of what they have observed and draw conclusions.

For comparison, collect several of the prediction graphs and the experiment graphs from the students and post them on the wall. As students look at the experiment graphs, lead a class discussion. Questions like these will help students construct their understanding of the cooling process.

- ? **How do the graphs show what happened to the temperature of the water?**  
*The temperature dropped rapidly at first, then more slowly. The graphs show a steep downward curve that started to level off as the water approached room temperature.*
- ? **What was the temperature of the water at the start of the experiment?**  
*The water was boiling in the pot (100°), but cooled slightly when poured into the cups. Students can report their initial readings.*
- ? **What was the temperature of the water after 1 minute? 5 minutes? 15 minutes? Did every team get the same results?**
- ? **Did the water cool at a constant rate? What do you notice about the shape of the line?**  
*The line is not straight because the water did not cool at a constant rate.*
- ? **When did the water cool the most?**  
*The cooling rate was highest at the beginning where the curve is steepest. At this point, the difference between the water temperature and room temperature was greatest, so the heat energy flowed quickly.*
- ? **When did it cool the least?**  
*The cooling rate was lowest at the end as the water slowly approached room temperature. When the temperature difference is small, heat flows more slowly.*
- ? **The graphs show the temperature during a period of 20 minutes. Predict the temperature after 30 minutes. Explain your logic.**  
*The temperature will continue to go down, but at a slower and slower rate. Once the water reaches room temperature, it will stay there.*
- ? **Predict the temperature after 60 minutes, 100 minutes.**  
*The temperature will remain constant at room temperature.*

### Cooling Experiment

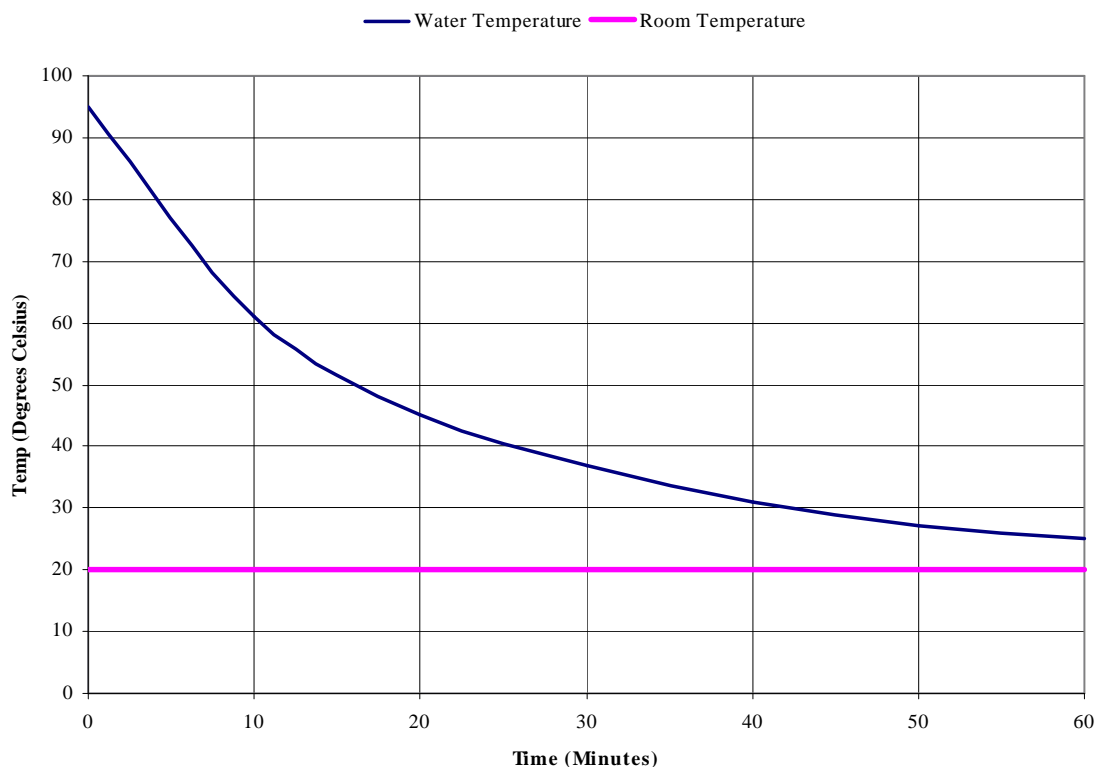

*This graph shows how the water temperature would approach room temperature if students ran the experiment for a longer time.*

Ask students to revisit their original prediction graphs.

- ? Do any of the graphs look alike?
- ? In what ways were the predictions correct?
- ? How were the actual results different from the predictions?

#### **Predictions Revisited**

Students need to know that it does not matter if their original predictions were correct or not. What is important is that they made a prediction. It is also important to have students share what they were thinking prior to the experiment and to compare those thoughts with their thinking after the experiment.

Wrap up by reviewing and explaining the experiment in a guided dialogue with the students.

- The water started off hot (heat energy was added in the kettle).
- The temperature of the water was much higher than the surrounding air temperature, so heat energy started to flow out of the water at a fast rate.
- This loss of heat made the water cooler, so temperature difference between the water and the air was a little smaller. Therefore, the heat energy started to flow out of the cup at a slower rate.
- This process went on and on, until the temperature of the water was the same as the temperature of the room. This is the reason that the graph curved a lot at the start and then got flatter as time went by. This pattern of change is called *exponential decay*.

? **Can you think of other examples of heat transfer that fit the pattern we observed?**

- *An ice cream cone melts much faster on a hot day than in winter. The heat energy flows more quickly when there is a bigger gap between the temperature of the ice cream and the temperature of the air.*
- *A house loses heat more rapidly on a cold winter day. If the furnace does not come back on, the house will eventually cool down to the outside temperature as the heat escapes. The same principle works for an air conditioned house on a very hot day, only the heat transfers into the house rather than out of it.*

? **Can you think of other examples of exponential decay?**

- *Excitement about some toys: When the toy is new, you are very interested in it, but as time goes by, you use the toy less and less, until it sits on the shelf with all the other toys.*
- *The value of a car as it ages: The value drops rapidly at first and more slowly in later years.*
- *Exponential decay is common in many other systems. Students who play the Mammoth Game (Lesson 3) will recognize the same pattern in a declining population.*

### Notes

<sup>1</sup> For a simple system dynamics computer model of this cooling experiment with complete instructions for using it with students in the classroom, see “It’s Cool: An Experiment and Modeling Lesson” by Ticotsky, Quaden and Lyneis, 1999, available through the Creative Learning Exchange at [www.clexchange.org](http://www.clexchange.org).

For more advanced lessons and background on cooling experiments and computer modeling see the “Cooling Cup Packet” by Celeste Chung and Albert Powers, 1993, also at [www.clexchange.org](http://www.clexchange.org).

Name \_\_\_\_\_

## COOLING PREDICTION

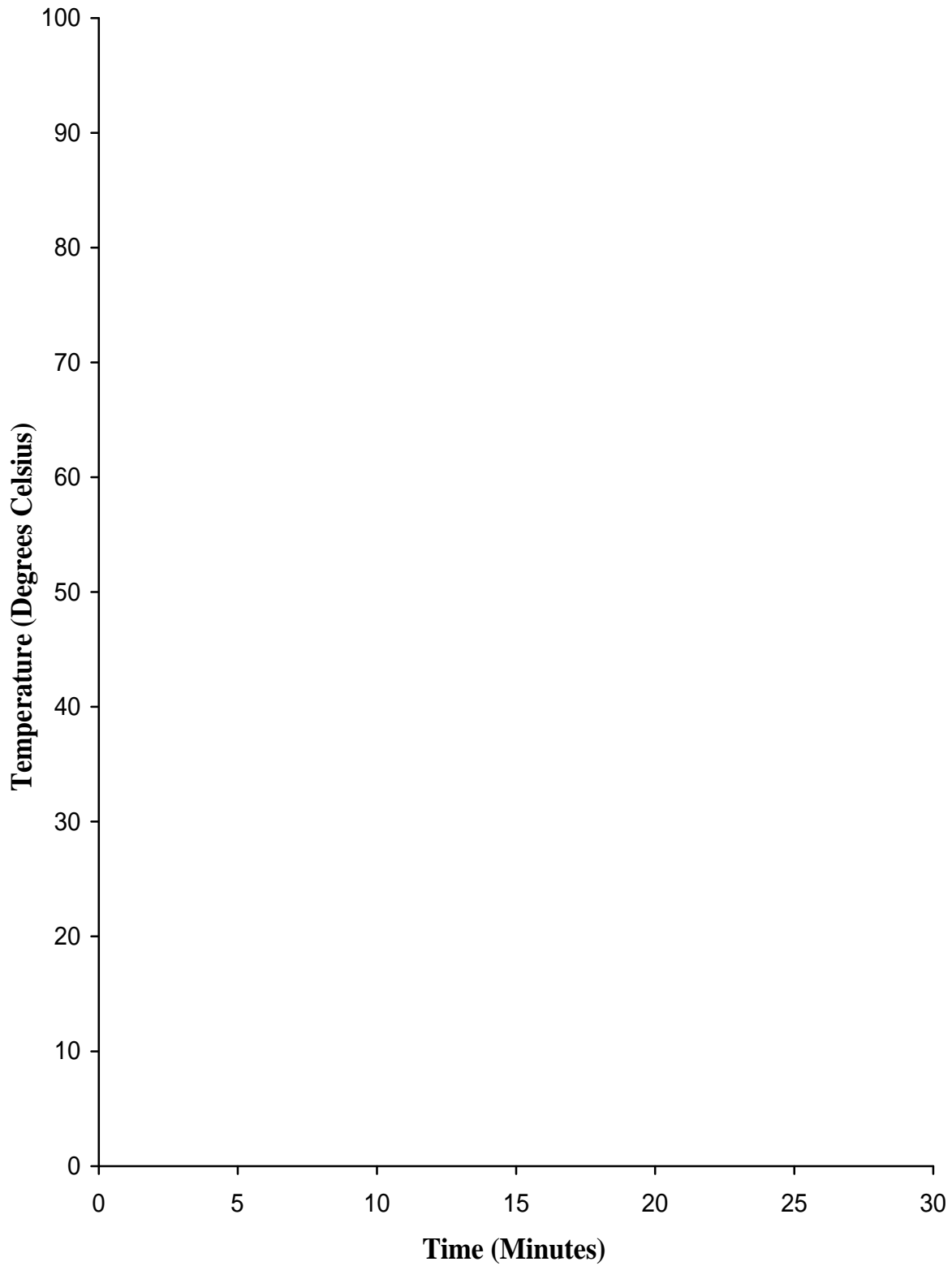

Name \_\_\_\_\_

### COOLING DATA

TIME (Minutes)	TEMPERATURE (Degrees Celsius)
Start	
1	
2	
3	
4	
5	
6	
7	
8	
9	
10	
11	
12	
13	
14	
15	
16	
17	
18	
19	
20	
21	
22	
23	
24	
25	
26	
27	
28	
29	
30	

Name \_\_\_\_\_

## Cooling Experiment

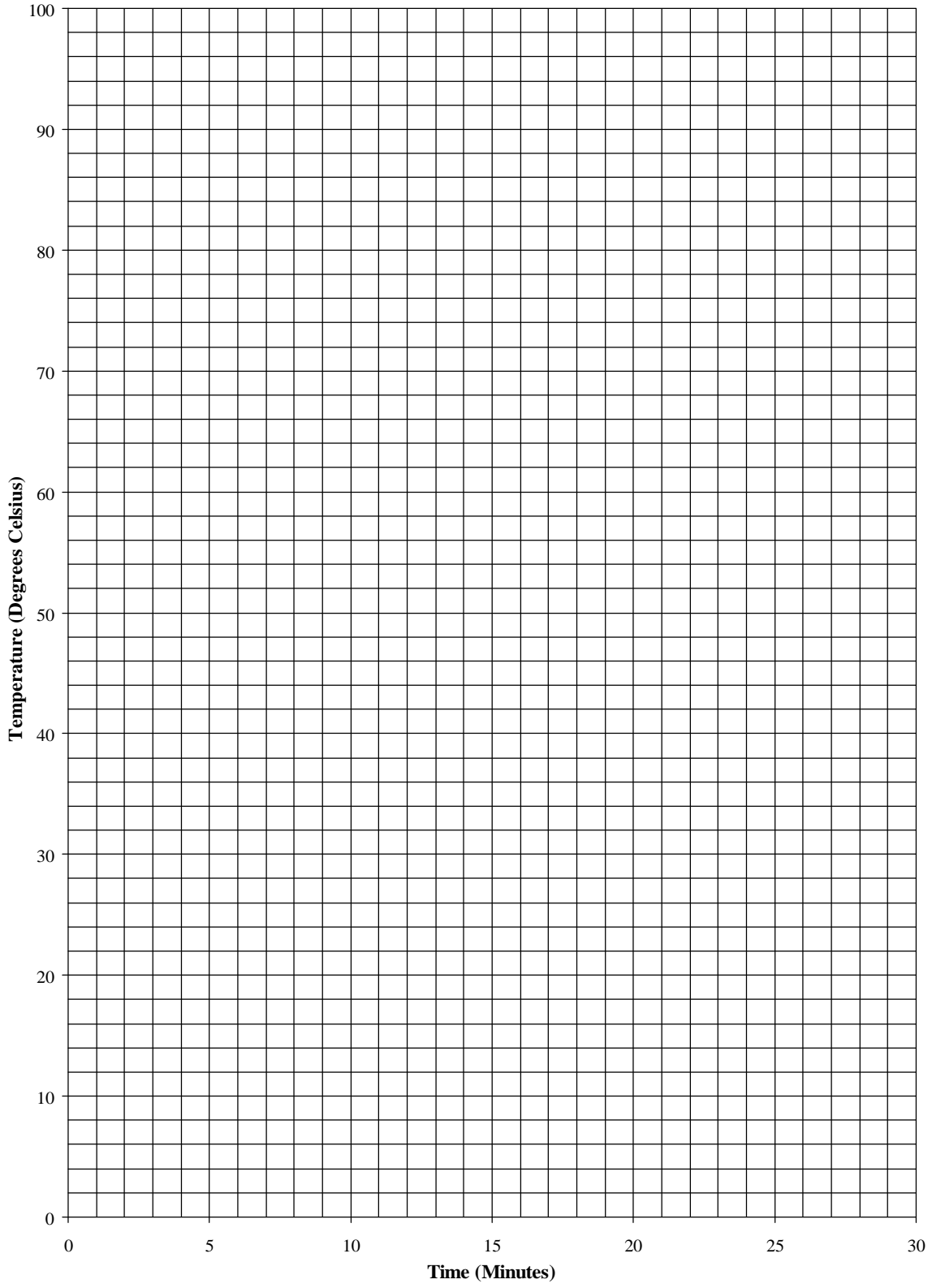

# It's Cool

*This lesson builds on the classroom activities described in **The Shape of Change**, by Rob Quaden, Alan Ticotsky and Debra Lyneis, 2004, The Creative Learning Exchange. You can download the text of the original single lesson or get the graphics and layout in the complete book from the CLE at [www.clexchange.org](http://www.clexchange.org).*

## **The Shape of Change**

In Lesson 4 of **The Shape of Change**, students conducted a scientific experiment to measure, record and graph the changing temperature of a cooling cup of boiling water. See Pages 39-50 in **The Shape of Change** for the complete lesson.

## **Overview**

In the cooling activity, the stock is the heat in the water and the flow represents the loss of that heat into the air. However, unlike the birth and death rates in the Mammoth Game (the previous lesson on which this one builds), the cooling rate is not constant. As students observed in their experiment and graph, the water temperature dropped quickly at first, but as the difference between the water temperature and the room temperature narrowed, the rate of cooling decreased until the water eventually reached room temperature.

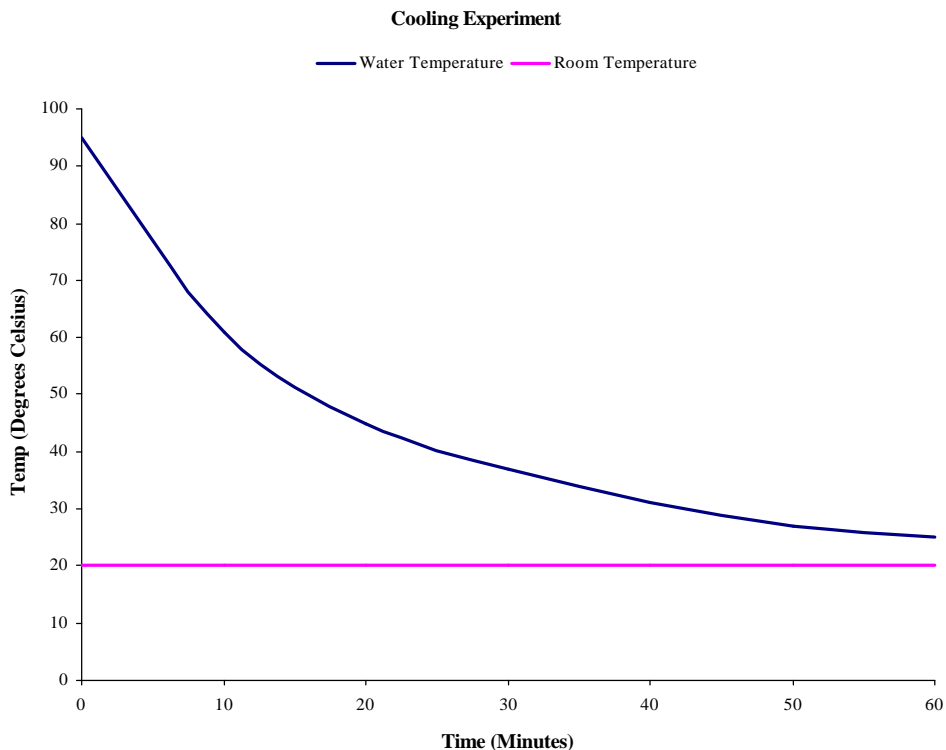

Doing the classroom experiment, students learned that heat always flows from an area of higher temperature to an area of lower temperature, flowing more quickly when the temperature difference is greater.

Building a stock/flow map of the cooling process will help explain why the temperature graph did not produce a straight line and why this exponential decay approached room temperature.

## Seeing the Structure

1. Ask students to identify the stock and flow in the cooling experiment.

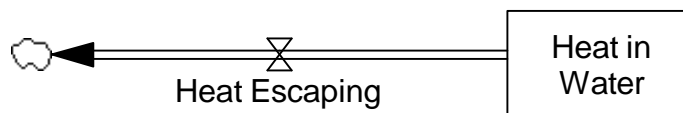

*Notice that the outflow is draining toward the left this time. Flows can go in any direction. The arrow tells the direction of the flow.*

2. Be sure students understand the difference between heat and temperature. (See “How It Works” on Pages 39-40 of *The Shape of Change*.) Heat energy accumulates and dissipates; it is measured in degrees of temperature. Connect the stock Water Temperature to show that we would need to convert the heat energy to degrees Celsius.

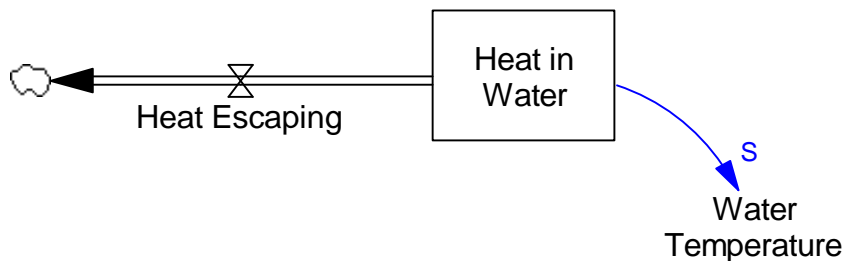

3. Ask students to name factors that affect the rate at which heat escaped from the water. Factors typically mentioned by students include the insulating properties of the container, the surface area of the water exposed to air, the shape and size of the container, and so on. For simplicity, bundle these factors together into one variable labeled “Cooling Rate” or a similar name to represent the effect of all these factors on how quickly the heat escapes the water. The higher the rate, the faster the heat escapes.

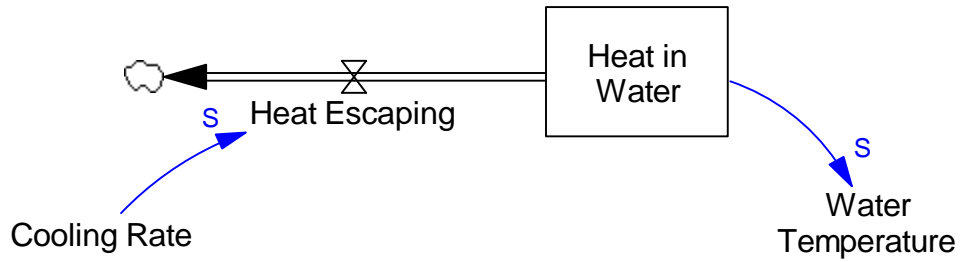

4. Remind students to think about the shape of the temperature graph. The cooling was steepest at the beginning when the difference between the water temperature and room temperature was greatest. Later, when the difference was smaller, the cooling rate slowed down. Add Room Temperature to the diagram.

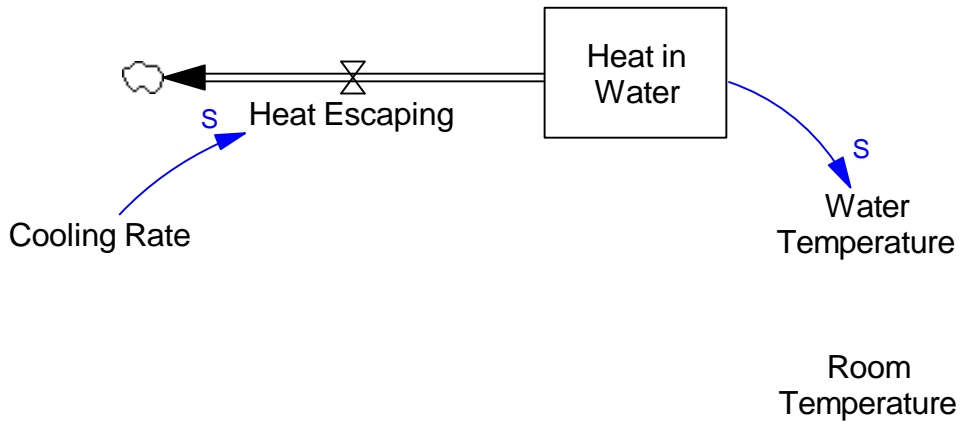

5. Remember that the difference between the room temperature and the water temperature determined how quickly the heat escaped. Add a variable named "Difference" to represent the gap between the two measurements. The higher the water temperature the greater the difference.

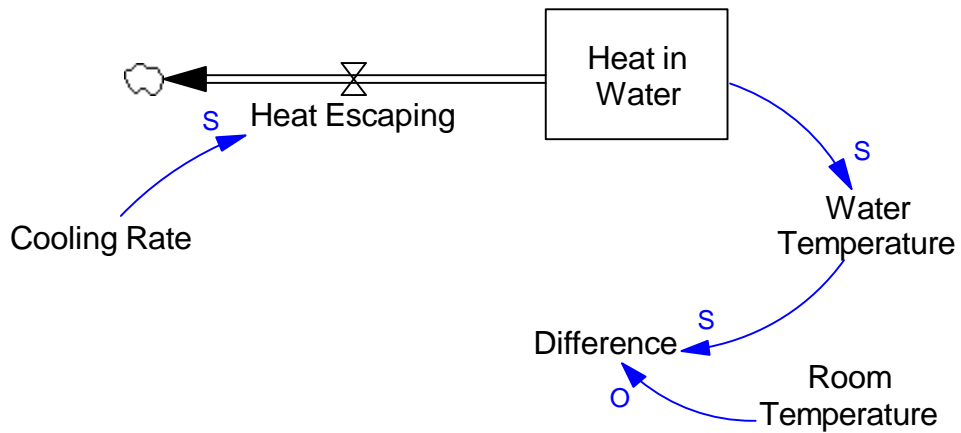

- Finally, the size of the difference between the water temperature and the room temperature affected the rate of heat escaping. When the gap was large, heat escaped quickly, as it did in the early stages of the experiment. As time passed, the room temperature stayed constant while the water temperature dropped, reducing the difference between the two measurements.

Connect “Difference” to the “Heat Escaping” flow to show that the temperature difference caused the rate of heat escaping to change – the greater the difference, the higher the rate.

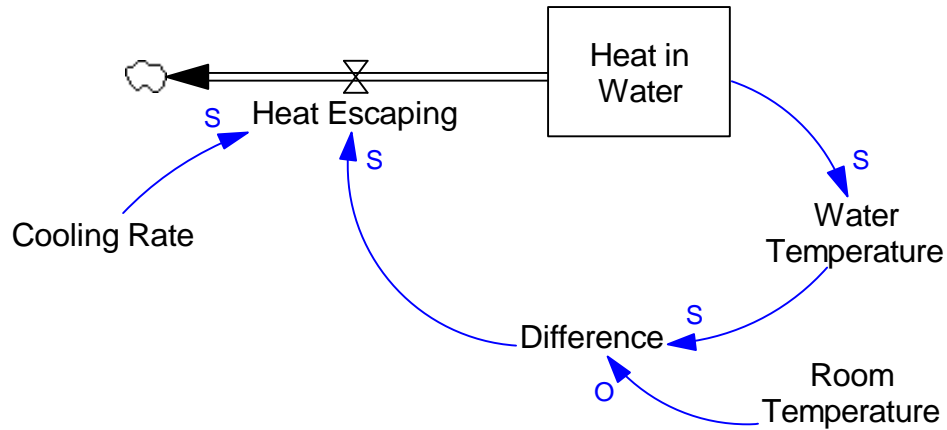

The stock/flow map now explains how the unique cooling factors of the container and the difference between the water temperature and room temperature affected the rate of cooling. It explains how the accumulation of heat energy dissipated over time.

- Trace the feedback loop in the stock/flow map using up and down arrows if necessary. When the stock of “Heat” **increases**, “Water Temperature” **increases**. Since “Room Temperature” is constant, the “Difference” **increases**. A larger “Difference” causes “Heat Escaping” to **increase**, which makes “Heat” **decrease** this time. As we learned in the previous lesson, when elements reverse in a feedback loop, the loop is **balancing**.

*The cooling experiment is an example of a **balancing feedback loop** at work. The water temperature approaches room temperature at a decreasing rate.*

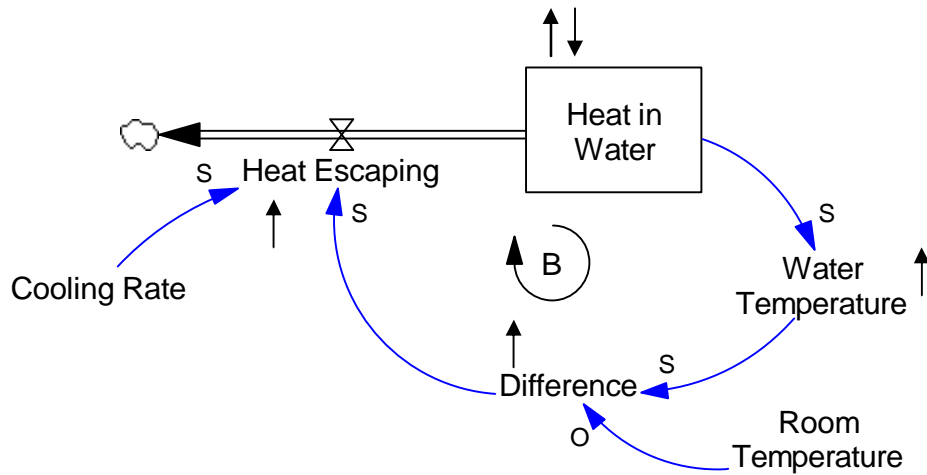

8. Look at the cooling graph again and relate it to the stock/flow map. The balancing loop produces an **exponential decay** graph of temperature. The graph curves with a high rate of decline at first and flattens, eventually approaching room temperature.

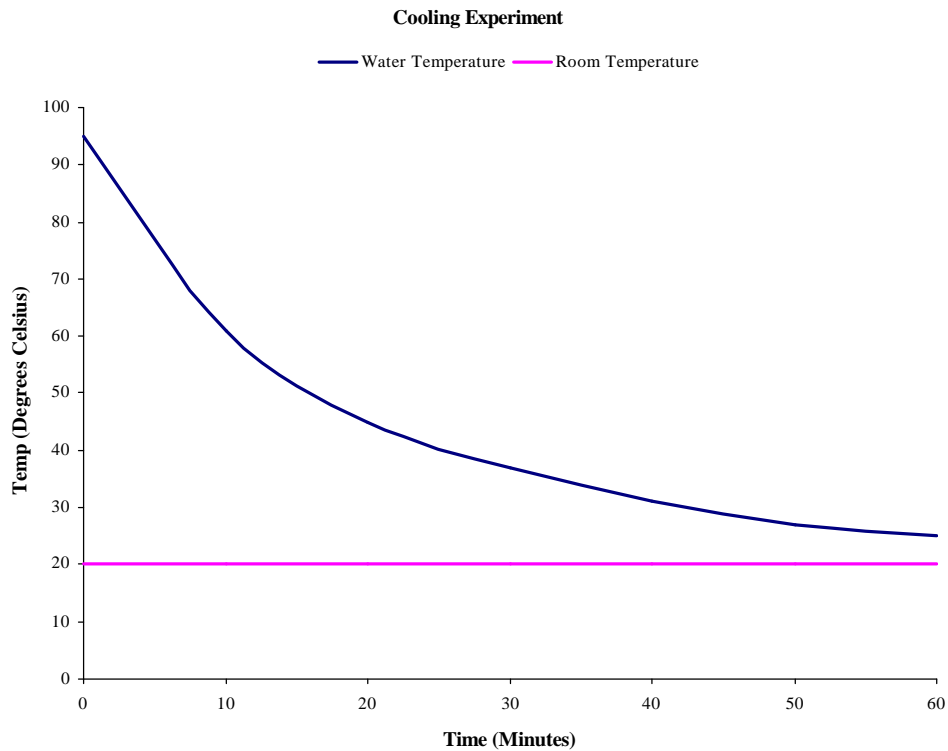

*This graph is like the exponential decay caused by the balancing loop in the Mammoth Game. When the herd was large, many mammoths died. As these deaths reduced the size of the population, there were fewer and fewer deaths each year, and the population slowly approached zero – extinction.*

? **In this lesson we measured the temperature of a cooling cup of boiling hot water. Why did the water approach room temperature?**

*The water approached room temperature because the heat was flowing out of the water and into the cooler air. It flowed most rapidly at the beginning of the experiment when the gap between the water temperature and the room temperature was the greatest. As the gap closed, heat escaped more slowly. When the water finally reached room temperature, it stayed at room temperature.*

## An Extension

For a further challenge, some students may be able to apply what they have learned in a broader way.

? **What would happen if we started with ice cold water instead of boiling hot water?**

*The heat would flow from the warmer air into the cooler water, again flowing most rapidly when the temperature difference was greatest at the beginning. Eventually, the water would warm up to room temperature and stay there.*

? **Does our stock/flow map apply to ice water too?**

*Yes, it does. To make it clearer, we would change “Heat Escaping” to “Heat Transferring” which means that the heat always moves from the warmer area to the cooler area whether you start with boiling water or ice water. The arrowheads on both ends of the flow show that the flow can go either way.*

*For boiling water, the heat flows **out** until the water reaches room temperature. For ice water, the heat flows **in** until the water reaches room temperature. The stock of heat increases.*

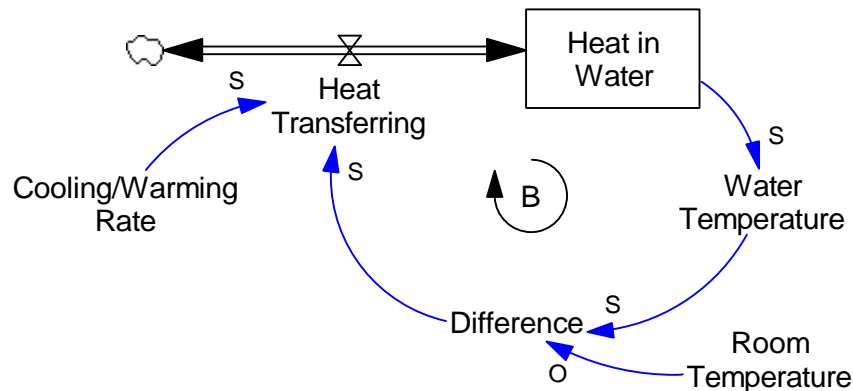

*An arrow head at both ends of the flow indicates that heat energy can flow into or out of the stock, depending on whether you start with very hot or very cold water.*

? **What would the graph of a warming cup of water look like?**

*It would be similar to the cooling experiment, except this time the water is approaching the goal of room temperature from below as it warms up.*

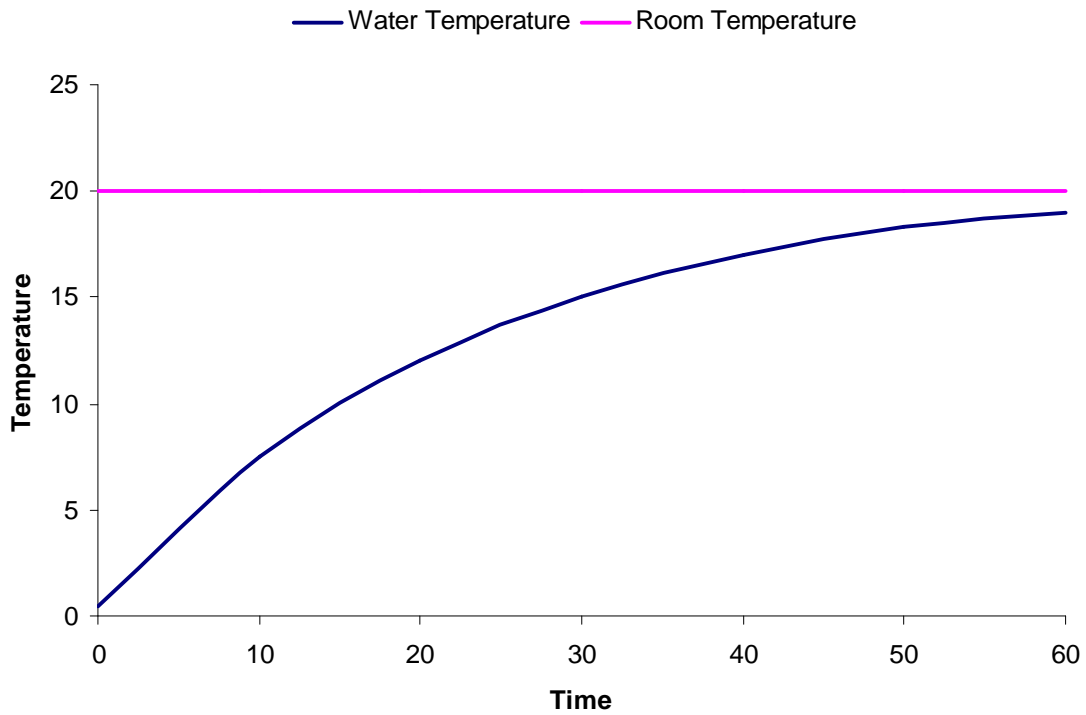

*For ice water, the balancing loop causes the water temperature to rise approaching room temperature.*

### A Causal Loop Diagram

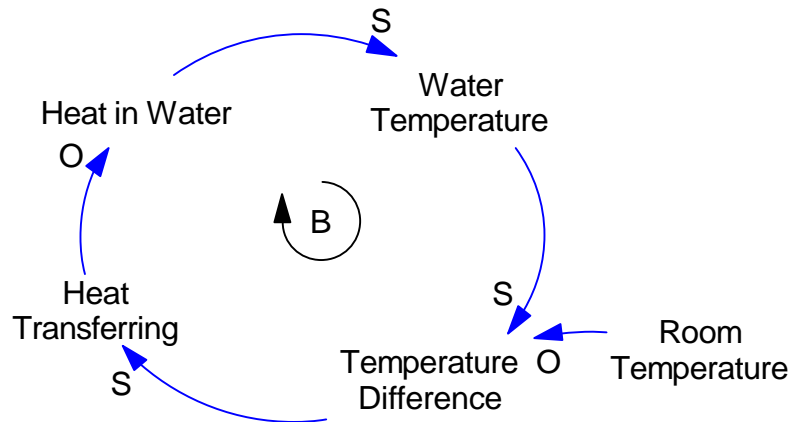

This diagram gives us a general picture of the balancing feedback loop – the water temperature adjusts to approach room temperature. Our stock/flow diagram gives us a more precise “operational” view of how the heat accumulates or dissipates over time. We use both diagrams to understand the behavior we observed and graphed.

### Another View

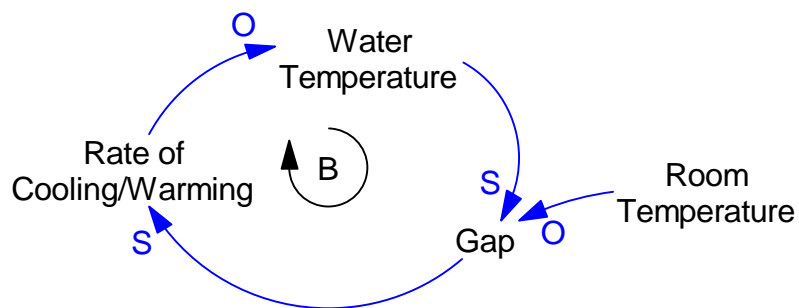

An even simpler generic depiction of the balancing loop could show the temperature adjustment without the intervening temperature/heat conversions. The rate of change declines as the gap closes, until the water temperature reaches the goal of room temperature. In this lesson, however, we included the conversions because the concept of heat energy as a stock was the focus of the science lesson.