



# the Creative Learning EXCHANGE

Volume 10, Number 2 - Spring 2001

## Expositions for Student Work in System Dynamics

Lees N. Stuntz

Two expositions for student work in system dynamics will be held this May, one on each coast. Each is a celebration of what students are learning with the tools and skills of thinking taught through system dynamics. The older exposition, SyM\*Bowl, is in its sixth year in Portland, Oregon. Originally a competition for high school students, it now is a celebration of the flowering of system dynamics in K-12 education. The newcomer, DynamiQUEST, started last year in the Northeast as an exposition for students in middle and high school to celebrate their work and experience coaching by adults with experience in the field. Both expositions are being held in May this year.

### DynamiQUEST 2001

The second DynamiQUEST will be held on May 11, 9 A.M.–3 P.M., at the new Campus Center, Worcester Polytechnic Institute. The only international undergraduate system dynamics program is situated at WPI, so the connection is exciting for both the DynamiQUEST participants and WPI. The DynamiQUEST organizing committee recognizes that students (and teachers) are at various places along the road to developing proficiency with thinking systemically and employing System Dynamics/Systems Thinking (SD/ST) to address complex issues and increase understanding. We seek to encourage students and teachers to develop an understanding of the use of

SD/ST tools. We all also know that we need an environment, free from the “winner/loser” constraint, where kids can receive feedback from other kids as well as from teachers and professionals well versed in SD/ST. DynamiQUEST creates a venue for both celebrating what has been done and providing encouragement for all to continue!

In this spirit, DynamiQUEST was launched last year. DynamiQUEST 2001 will provide a venue for students in Grades 5-12 to showcase work in

which they have employed the tools and method of system dynamics. This effort has several purposes:

- Provide a way for students to meet other students and see what they are doing
- Permit teachers from different schools to see evidence of student work in ST/SD
- Provide a venue for teachers and kids to network
- Have some fun and celebrate with kids!

*Expositions continued on page 15*

## INTERDISCIPLINARY, NATURALLY

### Fifth in a series of “What It’s Like to Be a Pioneer”

Prepared with the support of the Gordon Stanley Brown Fund by Debra Lyneis

*Jay Forrester has suggested that we could speed the spread of learner-centered-learning and system dynamics in K-12 education by sharing tales of “what it’s like to be a pioneer.” It might help others who are starting out, or just curious, to know about other teachers’ experiences, triumphs and tribulations. This paper presents just one little vignette. Please let Deb Lyneis know ([LyneisD@clexchange.org](mailto:LyneisD@clexchange.org)) if you have other tales to share.*

Schools are always looking for ways to make their curriculum interdisciplinary, but sometimes attempts to link together separate elements of a traditional curriculum can feel contrived. The subjects may be

covered at the same time, but they don’t really work together. With system dynamics modeling, however, work becomes genuinely interdisciplinary by nature.

Teachers in the Carlisle, Massachusetts Public Schools discovered this by accident several years ago. Eighth grade math teacher Rob Quaden and science teacher Jim Trierweiler had been introduced to system dynamics and were beginning to consider its application in each of their classes. System dynamics seemed like a good idea, but it also seemed very difficult and they were not sure just where it would fit in the curriculum.

*Interdisciplinary continued on page 16*

## UPDATES...

Catalina Foothills School District  
by Lees Stuntz

After 13 years, the Catalina Foothills School District has significant integration of system dynamics tools and practices as a methodology to support district goals throughout their K-12 district. As is the case in many dynamic systems, there have been periods of growth and stagnation in the use of SD in the district, but the progress trend is clearly upward.

I traveled to Tucson in February and spent two days in the schools. One of the most exciting areas recently has been in elementary classrooms. The two elementary mentors, Joan Scurran and Julie Guerrero, are constantly busy in the four elementary schools. They work with teachers to plan lessons, and then either teach with the teachers or support them if they feel comfortable teaching the lessons themselves. One huge impediment to integrating new teaching tools into the elementary classroom is the lack of planning time that many elementary teachers experience. This hasn't stopped many teachers, though, from making time to plan with the mentors.

Joan and Julie are working across a variety of grade levels. They work extensively with the Challenge program for the gifted in 4<sup>th</sup> and 5<sup>th</sup> grades—which are pullout classes. Some of the curricular work developed in the Challenge classes, such as a fourth grade electricity lesson, has now been implemented in the regular classroom setting.

I observed two other lessons while I was there. One was a lesson in Arizona history in the fourth grade, and the other was an exciting third grade discussion of a mouse population model that the students had developed with Julie and were now translating into a coyote population model. It was evident that there had been extensive preparation,

## EDITORIAL

It is very exciting, for the second year in a row, to have events on each coast celebrating the work of K-12 students using the thinking skills of system dynamics! This May will be a busy time with the revamped SyM\*Bowl and the fledgling DynamiQUEST taking place in the first two weeks. I would urge any of you who are within traveling distance to consider encouraging your students to participate in either of these two events. In both venues, they will be able to interact with other students, experienced teachers and experienced system dynamicists. Please read the article discussing these expositions, and check out the website, [clexchange.org](http://clexchange.org), for even more details.

As the spring progresses, do take the time to enjoy it. If you have the time this spring or summer, tell us what you are doing. We are always looking for articles for the newsletter. We also have a survey up on our web site, and would appreciate any feedback you can give to us to make it better.

*Lees Stuntz (stuntzln@clexchange.org)*

with careful coaching and teaching, to get the class to the point that they had a mouse population model of their own that they knew well enough to transfer over to a coyote model.

The classes in the middle schools, Orange Grove and Esperero, continue to make good use of the systems approach. One recent development has been at Orange Grove, where the serious illness of a mentor has had the effect of some teachers being willing to stretch and try more things on their own. I was able to sit in a 6<sup>th</sup> grade advanced math class at Esperero and enjoyed re-learning  $y=mx+b$ . The students were highly engaged and motivated both in the classroom portion of the lesson and in the computer lab portion. I didn't hear any complaints about word problems!

The Catalina Foothills High School was established eight years ago with the use of system dynamics included from the school's inception. At this point, there are many applications in the science curriculum, especially in chemistry and biology. Although they lost two English teachers who were avid fans of the SD

approach, one of the newer English teachers at the high school is now using a systems approach with the novel, *Native Son*, and is enthusiastic about expanding his repertoire. Other uses continue in PE, social studies, and art.

A positive feature of the Catalina Foothills/Waters Foundation approach of offering training and on-going support and then letting the teachers who are interested seek assistance, is that the teachers who come and ask for help are ready to learn and use SD in their classroom. One thing that does come with this territory, however, is that when teachers who have been using SD leave, there may be a lag before someone else with a similar interest shows up in that grade and discipline. In spite of that obstacle, committed teachers and staff continue to be effective advocates and practitioners of the systems approach within the district.

*Our thoughts and prayers go out to Ron Michalak, a systems mentor in the Waters Project for a number of years, who is fighting cancer.*

✧

## System Dynamics Models Created by High School Students

by Diana M. Fisher, presented at the 2000 International System Dynamics Society Conference in Bergen

For the past nine years a system dynamics modeling course has been taught at Franklin High School in Portland, Oregon. Two years later, a formal systems modeling course was taught at Wilson High School in Portland. Three years after that, a systems modeling course was taught at LaSalle High School in Portland. Each of these schools currently has a two year program offered, with Franklin offering a third year course for the first time next year. A significant subset of high school students in these three schools have indicated such a strong interest in learning to create system models that these courses continue to grow and the curriculum expands. In each of these high schools, systems modeling has also made inroads into the regular curriculum of mathematics, physics, social studies, biology, physical science, environmental science, and even religion classes. High schools in Beaverton, Oregon, Vancouver, Washington, Roseburg, Oregon, Fairbanks, Alaska, and McAlister, Oklahoma are a few other locations that have system dynamics modeling evolving in their curriculum.

What is even more apparent, as teachers at these schools communicate with each other, is that high school students can create models addressing significant issues, have the skill to create such models correctly, and can explain their work in such a way that it is readily apparent that they know about which they speak. Student papers have been read by people both within and outside the education community. The SyM\*Bowl<sup>1</sup> systems modeling competition for high school students, now in its fifth year, selects six judges annually to read some of these papers and query the students on their models. Of the six judges, three are professional modelers and three are teachers. Barry Richmond, president of High Performance Systems, was a judge during year four and year five. He commented last year:

*I was in awe of the breadth of topics the students had taken on and of the origi-*

*nality and ingenuity they showed in pursuing their diversely chosen arenas of study. I developed a tremendous respect for the general quality of thought, insight generated, and clarity of expression evidenced in the work, as well as for the sheer magnitude of effort that must have been put forth by most teams. Finally, I experienced a deep sense of joy for the flexing of intellectual muscles, and the soaring of intellectual spirit these students were demonstrating. This work was EXACTLY the reason STELLA was created—to give people the freedom to think in a more rigorous way about whatever it was they wanted to think about!*

With this said, the quality of student models has been an evolutionary process. Early models exhibited some raw mistakes in concept and execution. Each year the models improve. A significant part of this improvement has to do with the fact that the teachers are learning more about what constitutes good modeling practice and what qualities a good model must exhibit. Dr. George Richardson<sup>2</sup> has made a significant impact on many of these teachers. He has taken time to give them formal instruction on several occasions, after which the teachers collectively felt their ability to analyze and design correct system models improve substantially. His work is evidenced by the improvement made in the character and structure of the models their students have subsequently produced.

What follows are a couple of examples of models

that exhibit some serious mistakes that were made in the early years of the modeling classes and a larger set of good models that are more recent products of the modeling classes. The mistakes are presented in deference to Professor Jay Forrester, who feels people learn a significant amount by viewing the mistakes of others. The examples of good models are presented to show the quality of model that students can produce.

### Housing Availability Model

This model was an attempt to capture the land constraint on a growing population in a city. The students located the data identifying the current available land, zoned for residential property, in Portland, Oregon. They determined Portland's current population and net growth rate. They wanted to determine how long there would be space available to build houses for this growing population. More than one mistake is apparent in this model but what merits its inclusion is the trigger mechanism.

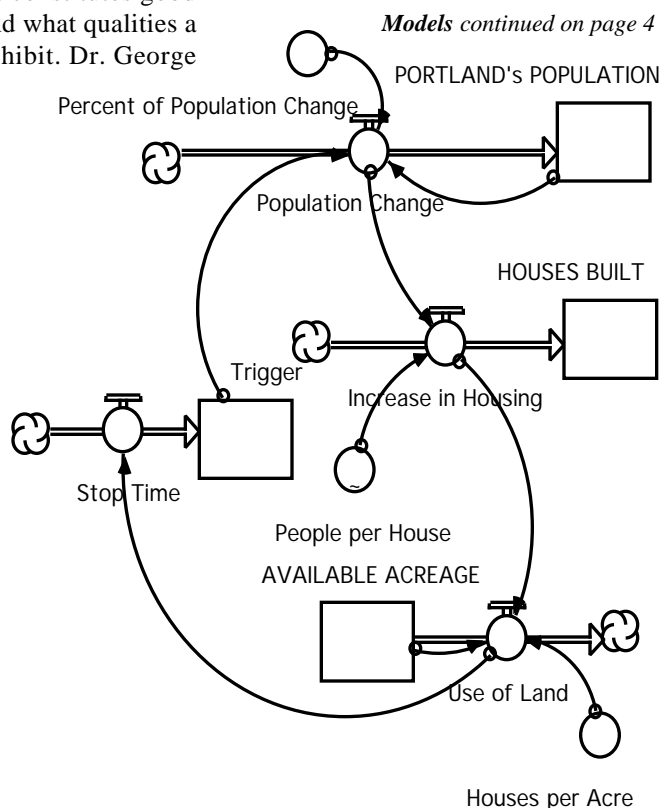

Figure 1: Housing Availability in Portland, Oregon

# Models Created by High School Students *continued from page 3*

The students wanted the population to stop growing when there was no longer space available to build houses for these people. The implementation of this concept in the model was to immediately turn off the population growth as soon as all land was consumed. Dr. George Richardson took one look at the graph and circled the sharp transition points in each curve. He said the real world almost never transitions in sharp curves. He then took the teachers through the classic urban growth model and introduced “multiplier” or “effect ...” factors and how to model transitions using a flexible influence graphical component. It was an important lesson, one translated to all second year modeling courses and to those more advanced lessons for the accelerated students in first year of modeling.

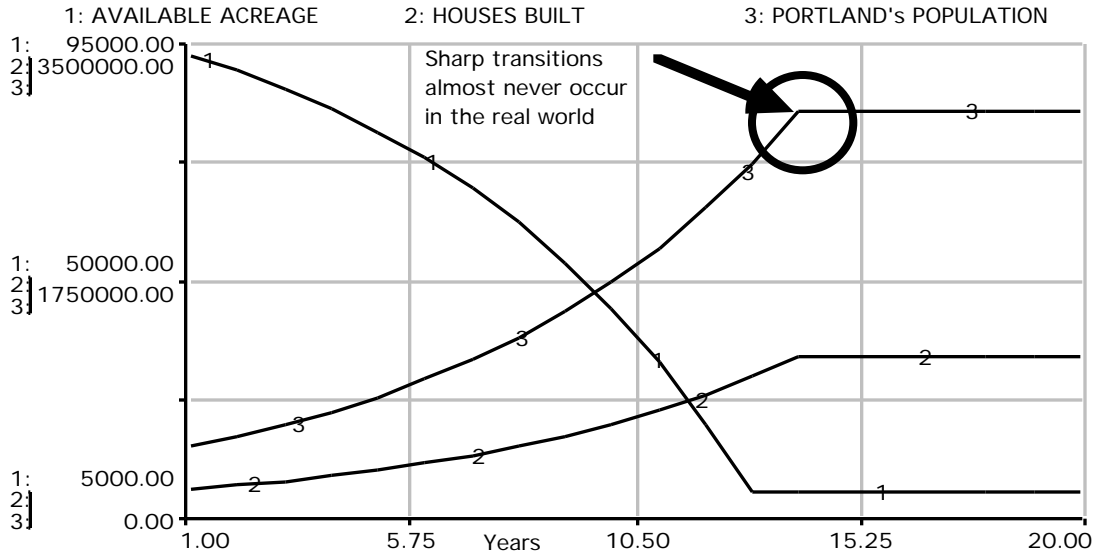

Figure 2: Graph of Housing Availability, Land Availability, Population Growth in Portland, OR.

in the “G” converter to represent the universal constant in the equation for the gravitational force between two objects. As is often the case, the students found the formula in a book and used the number without regard to the units involved. When all values were recalculated, with

attention to dimensional consistency, the correct shape for the path was displayed by this model. Although the instructors had been reminding students about dimensional consistency, it soon became an obsession passed from teacher to student every year, in every class.

## Earth’s Orbit Around the Sun Model

Another model, predating the previous example, attempted to replicate the behavior of the elliptical pattern of the orbit of the earth around the sun. The mistake in this model is not apparent from the diagram structure. As a matter of fact, it was the students’ conviction that the model must be designed correctly since the diagram made sense. The graph of the path, however, was consistently linear. The students rechecked the numeric values. They could not find the error. Finally, the question about dimensional consistency was raised. The students had placed a value

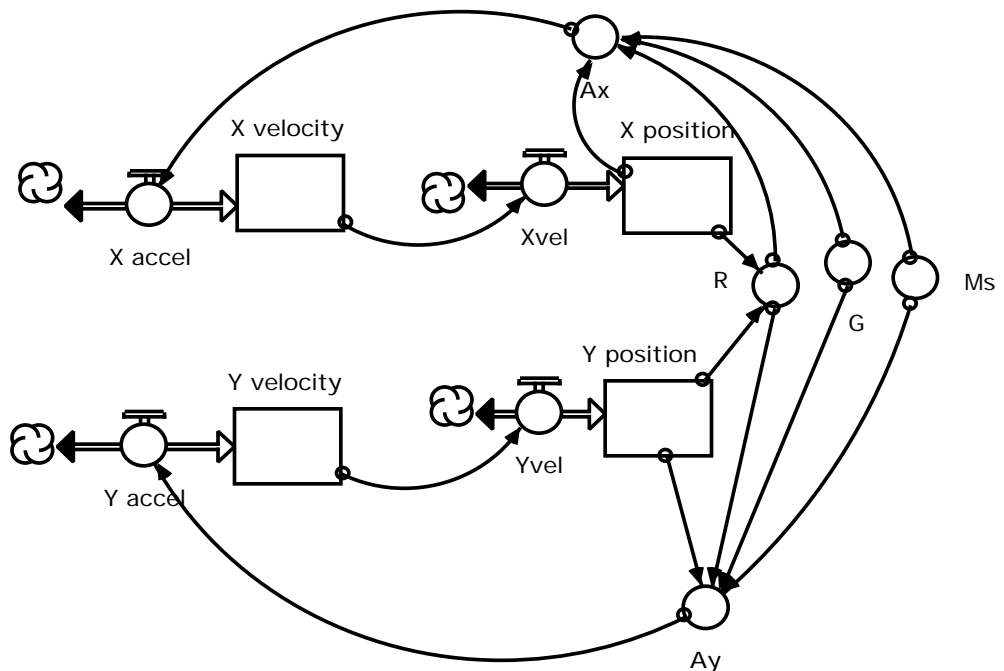

Figure 3: Orbit of the Earth Around the Sun

**Time of Death Model**

The model below won first place in the first SyM\*Bowl competition in 1996. The students who created this model had taken the forensic science course offered at Franklin High School and wanted to know more about how coroners determine the time of death.

There were two main reasons this model was worthy of distinction. The first was the model's structure. Core structures exhibiting classical behavior patterns over time are central to the instruction in the modeling courses. The students knew that the behavior should be convergent and started with a structure that would produce such a behavior. After conversing with a local coroner, they learned that there were over a dozen factors that are considered in determining the time of death of a corpse. The students knew they could not include all the factors, so settled on three that made sense to them and that they thought they understood well enough to include in the model. The factors included were ambient temperature, the weight of the body, and whether the person wore dry clothing, wet clothing, or no clothing at the time of death. Including the ambient temperature was not difficult, since it represented the target value to which the body temperature converged. The decrease in body temperature was inversely proportional to the body weight. But, how to determine the clothing factor?

The second reason this model was given recognition was the fact that the students conducted a simple experiment to determine the clothing factor value. They took three empty milk jugs and filled them each with water of about 98 degrees Fahrenheit. Around one jug, they placed a dry towel, around the second, a wet towel, and around the third, no towel. Then they recorded the decrease in temperature of

the water in each jug every fifteen minutes for three hours. From this they determined a clothing fraction to associate with each clothing scenario.

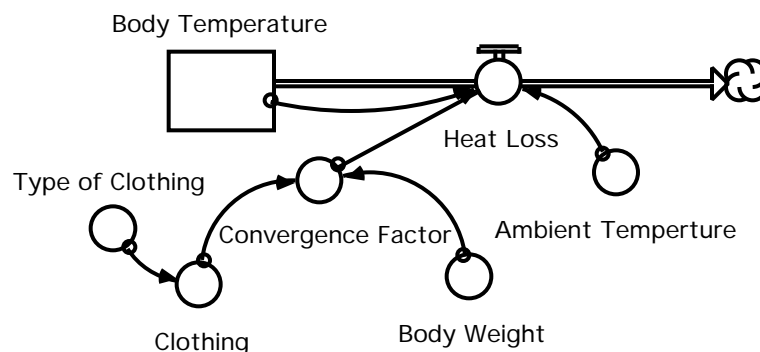

Figure 4: Determining the time of death of a corpse

**Consumption of Alcohol Model**

Although the following model was not created early enough in the school year to be included in the SyM\*Bowl competition, the students did excellent research and created a model which, according to Dr. Ed Gallaher, models the pharmacokinetics of alcohol absorption and metabolism very well. Dr. Gallaher was the professional the students consulted when they could not understand some of the formulas they encountered in their research. Many scenarios involving the pharmacokinetics of

alcohol can be tested using the model. The amount and type of alcohol consumed can be altered. Particularly, the difference between consuming alcohol that is carbonated, like beer, or concentrated, like whiskey, or both carbonated and concentrated, like champagne, can be studied. Whether the drinker is male or female, a moderate drinker or an alcoholic, a large person or a small person can be regulated. Any combination of the previous factors can be considered. When Dr. John Sterman<sup>3</sup> first observed this model diagram, he identified an impor-

*Models continued on page 6*

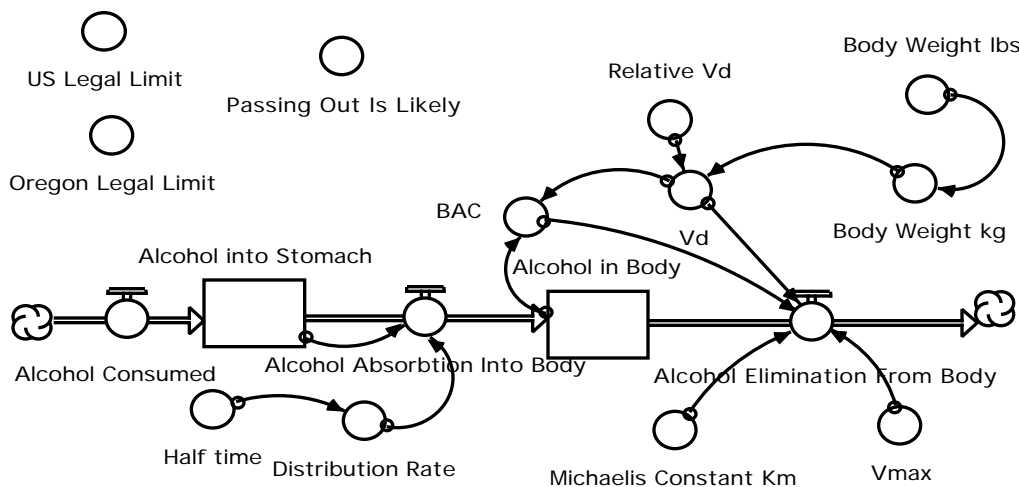

Figure 5: Pharmacokinetics of Alcohol Consumption

## Models Created by High School Students *continued from page 5*

tant feedback that could be added between the blood alcohol concentration (BAC) and the alcohol consumed. This was not included by the students at the time, because they never thought of that feedback. The teacher, however, did not forget the observation, and used it as an example of “soft” feedback for students to consider.

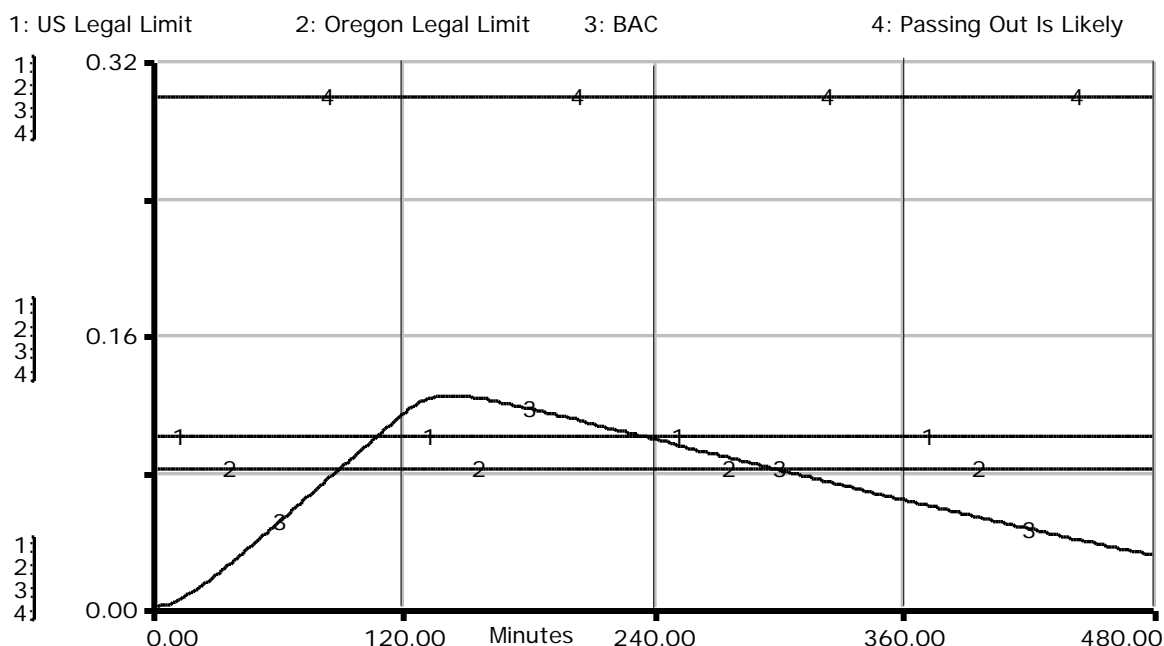

Figure 6: Blood alcohol level for a 125 pound male drinking six 12-ounce beers in two hours.

In addition to the factors mentioned above, students wanted to weigh the relative importance of each factor in determining how long a person needed to wait, after consuming a certain amount and type of alcohol, before their BAC was below the legal limit for driving. The length of time it took the BAC to decline was quite surprising to the students, as was the fact that the decline was largely linear rather than exponential.

The graph in figure 6 shows the blood alcohol concentration for a 125 pound (56.8 kg) male drinking six twelve ounce beers over a two hour period. Note that, upon cessation of drinking, the BAC level still rises, since it takes time for the final amount of alcohol to be absorbed into the rest of the body. Notice also that the elimination is primarily linear, as should be the case. Alcohol is a weak drug taken in relatively large quantity. Consequently, the drug receptors work at maximum capacity during most of the time the drug is in the system. The BAC level becomes exponential when it is at a relatively low level. Although that characteristic is not displayed in this graph, it does function correctly in this model.

### Tree Harvesting Model

The model below won first place in SyM\*Bowl in 1999. It is a simple population model, differentiating the age of the trees that would be harvested in Oregon. The students were interested in whether the current manual regeneration policies followed by the logging companies would produce sustainable forests in Oregon. Their model indicated the current practices would not sustain the forests. The students' scenario only considered harvesting trees via clear-cutting. Most of the data regarding replanting was obtained from a senior forestry management student at Oregon State University. He said that the replanting rate is designed to provide sustainability when considering the full range of harvesting practices currently in place in Oregon.

The students anticipated three leverage points in the model. The first was obvious, the harvesting rate. The second was the manual regeneration rate. The students found that even doubling the manual regeneration rate did not appreciably change the sustainability of the forests considered. Very few of the replanted trees survive, especially in a

clear-cut region. The third leverage point considered was the animal consumption of the seedlings. This produced the major surprise in the exercise of this model. The students were told that about 25 percent of the seedlings are lost to animal consumption each year. On government land, almost nothing is done to protect the seedlings. On private land where logging is allowed, significant effort is made to protect the seedlings. Those efforts include placing cones around the seedlings, placing salt-licks in the region for the animals, planting shrubs around the seedlings to deflect consumption of the seedlings. Altering the consumption by animals as little as 10 percent produced dramatic results. This was a surprise to everyone and certainly a basis for policy change in forestry management.

The paper these three students wrote for this model was featured in the first fall issue 1999 of the Creative Learning Exchange. The paper demonstrates not only an understanding of how the model functions but that students can communicate, to a diverse audience, the most important lessons learned from creating such a model.

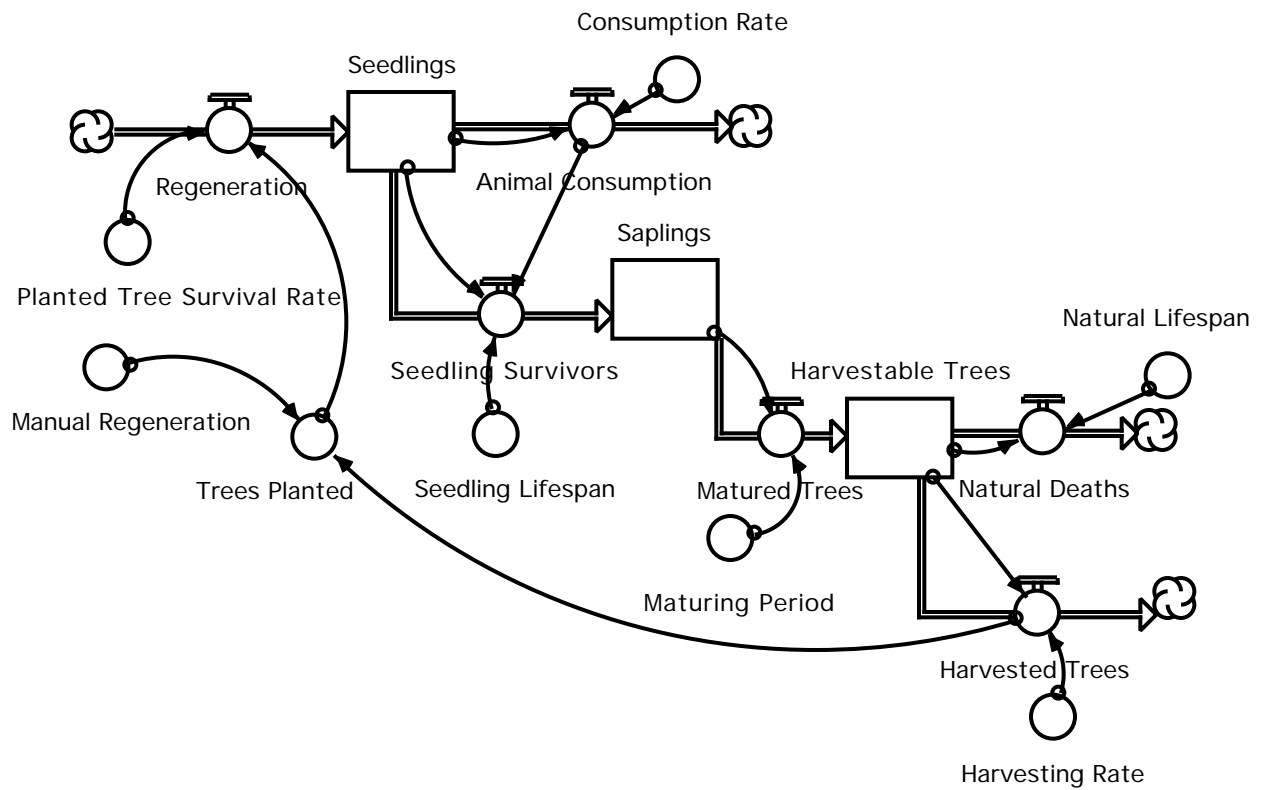

Figure 7: Testing Policies for Sustainability

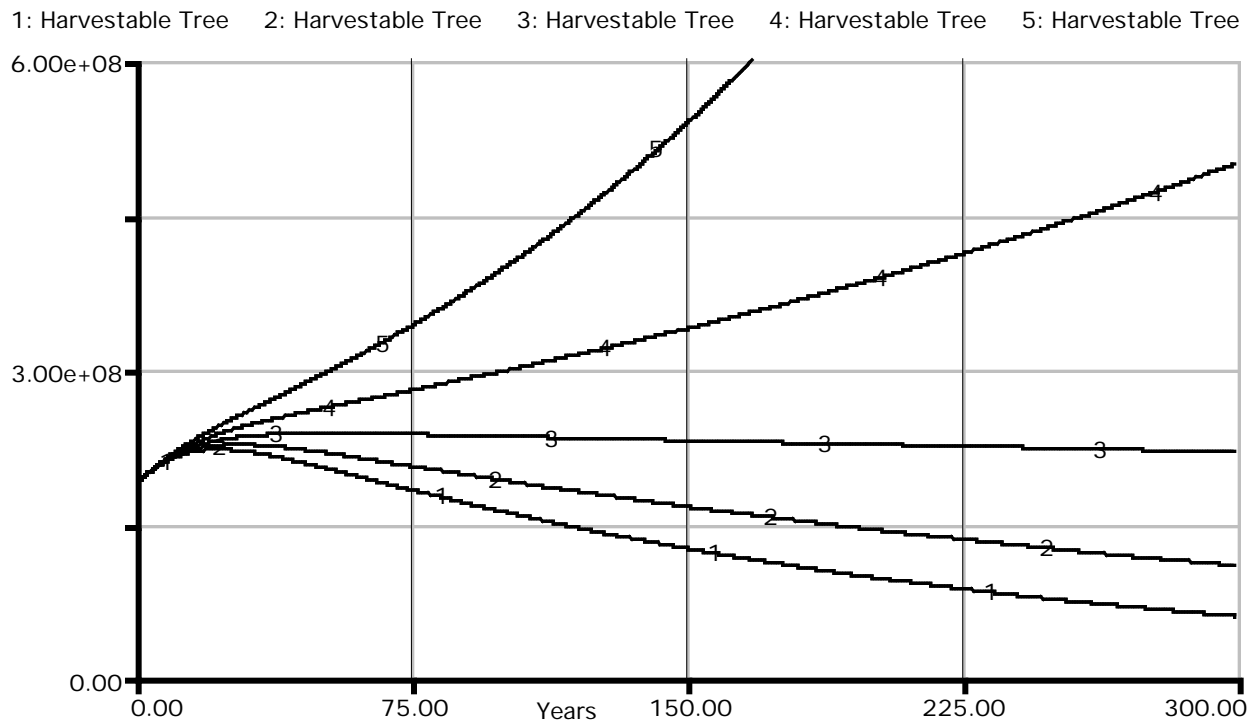

Figure 8: Changing consumption rate: graph 1 = 0.25, graph 2 = 0.20, graph 3 = 0.15, graph 4 = 0.10, graph 5 = 0.05

## Models Created by High School Students continued from page 7

### Cocaine Addiction Model

The study of simple drug pharmacokinetics is part of the regular curriculum for the first year modeling course at Franklin High School in Portland, Oregon. This is primarily due to the interest and support Dr. Ed Gallaher has demonstrated in pre-college education in the Portland region. He served as the main reference person for the student who created the following model on cocaine addiction. The student was stimulated to learn about the physical process of addiction because a person in her family was addicted to cocaine. Dr. Gallaher, consistent with his belief that it is important for a student to test many scenarios before he/she can understand why a particular behavior pattern occurs, had this student do dozens of trials with simple models over a period of about two weeks before zeroing in on the specific characteristics of cocaine addiction. The partnership made a lasting impression on this student.

The model demonstrates how dopamine, which is naturally released by the cells in the human brain, normally is reabsorbed shortly after release. The model has the dopamine released at regular intervals, and reabsorbed according to a rate 'Ku,' representing the fraction of dopamine outside the cell that will be taken back into the cell each time unit. This 'Ku' fraction depends upon how many drug transporters are available for the "uptake." Cocaine interferes with the reabsorption schedule of the dopamine. The affinity (stickyness) of the cocaine to the drug transporters causes fewer transporters to be available for dopamine reabsorption. When the dopamine is outside the cell it reacts with dopamine receptors. The extended time the dopamine is outside the cell causes the "high" sensation from using cocaine. The problem is that when dopamine is outside the cell for an extended period of time the dopamine receptors begin to break down. In the introduction of the paper the student explains,

*...My model shows how cocaine alters the amount of dopamine that is released to the synapse, and how long that dopamine is there. I am using my model to demonstrate an idea, or how a system works, and not to produce accurate data. The "high" a person experiences when using cocaine, is not the brain acting on the cocaine itself, but acting or responding to the amount of dopamine that is in the synapse. When dopamine is in the synapse, receptors respond to it. When dopamine is left in the synapse at a greater amount for a longer amount of time, the number of drug receptors breaks down, resulting in fewer receptors to act on the dopamine. As a*

*result, more cocaine is needed to create the same sensation as before. When more cocaine is used more drug receptors break down, reducing the amount that responds to the dopamine in the synapse, and more cocaine is needed the next time to receive the same sensation.*

This model tied for first in design, execution, and (paper) explanation of how the model works. Unfortunately, the presentation portion of the competition was very stressful for this student and she finished third in the overall SyM\*Bowl competition in 1997. The model is presented here as a recognition of the quality of her work.

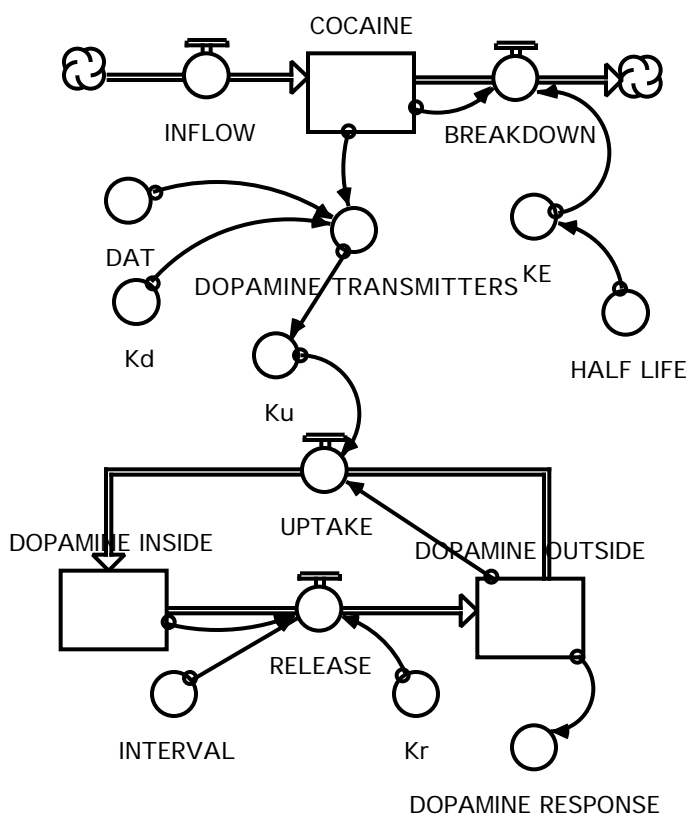

Figure 9: Cocaine Addiction Model

### China Demographics Model

The final model presented won the SyM\*Bowl competition in 1998. This student was very interested in China's one-baby policy and wanted to determine the ramifications of such a policy over time. He did extensive research, writing for and receiving original data documents from the Chinese government. The elegance of the approach this student used is one of the reasons this model was saved for last. The student started with a very simple population model, shown in figure 10.

With this simple model, the student tested different initial populations for China, starting each at the beginning of a specific decade and using associated birth and death rates for that time period. He projected each population to the year 2050. He noticed that each simulation run produced a very different final population and that if he started with the year 1960 the projected population actually decreased, rather than increased. (He explained the possible reason for this using historical context.) He decided almost immediately that he needed more detail in the model.

The initial simulation time for the second model was set to 1980 because the one-baby per family policy was introduced by the Chinese government in 1979. The population was separated into male and female compartments, since a shortage of females was projected as a result of this policy. The second stage model is shown in figure 11.

This model was an improvement. The male and female population projections to the year 2080 showed an ever widening spread and the total population did not grow as quickly as in the aggregated population model (figure 10). However, the second model did not produce results consistent with real data this student obtained from the Population Information and Research Center in Beijing. He felt that, to obtain the necessary results, he had to create a model

which included age distribution. He wanted to include infants separately, since they have an especially high death rate. He also surmised that "small differences in the infant mortality rate of females [could] have powerful effects in later years."

Two segments of his final model are shown in figures 12 and 13. The first model segment contains a high level view of the male population. An identical segment for the female population exists in the actual model but is not included here.

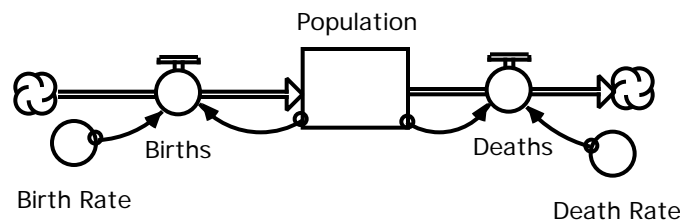

Figure 10: First stage China population model

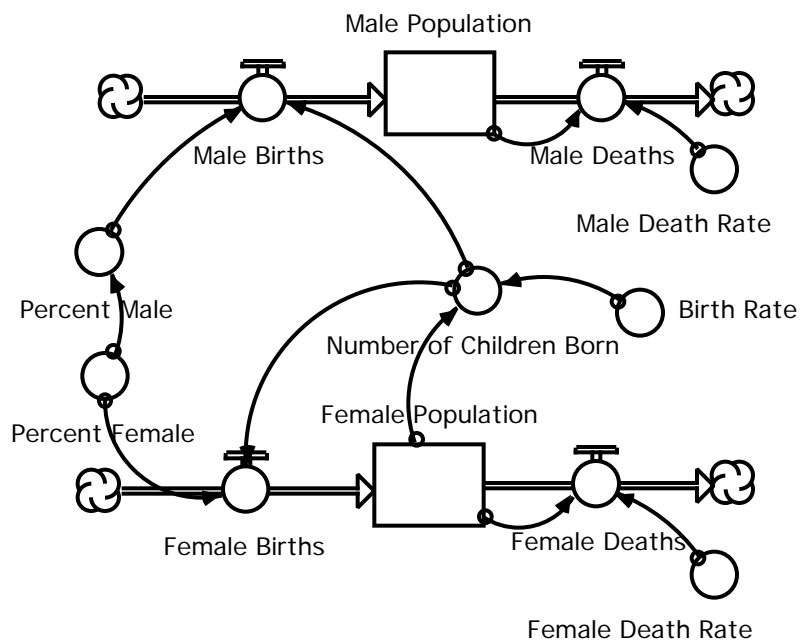

Figure 11: Second stage China population model

## Models Created by High School Students *continued from page 9*

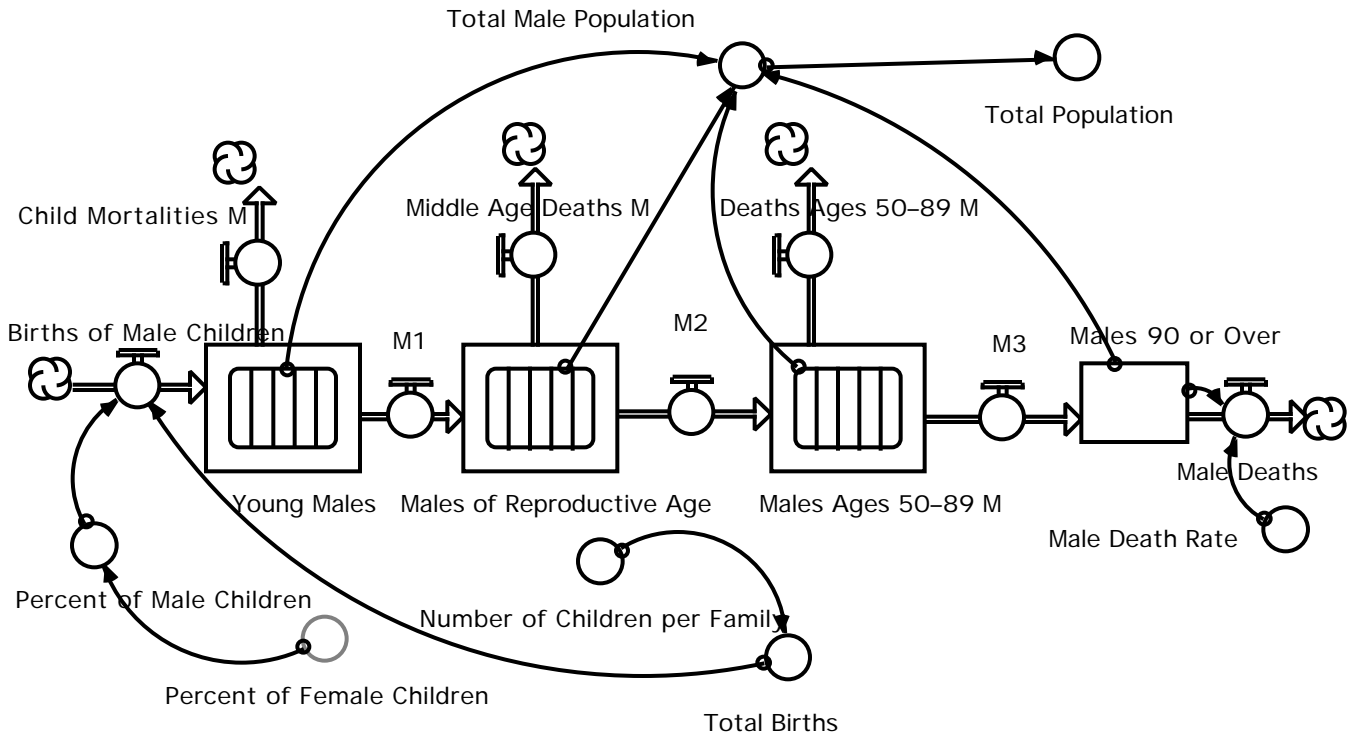

Figure 12: The Male Population Segment of the China Demographics Model

To maintain a simple view for the reader, yet include the detail he wanted regarding age group death rates

and maturation, he created submodels for each aggregated population group in the

top level. One example of such a sub-model diagram is shown in figure 13.

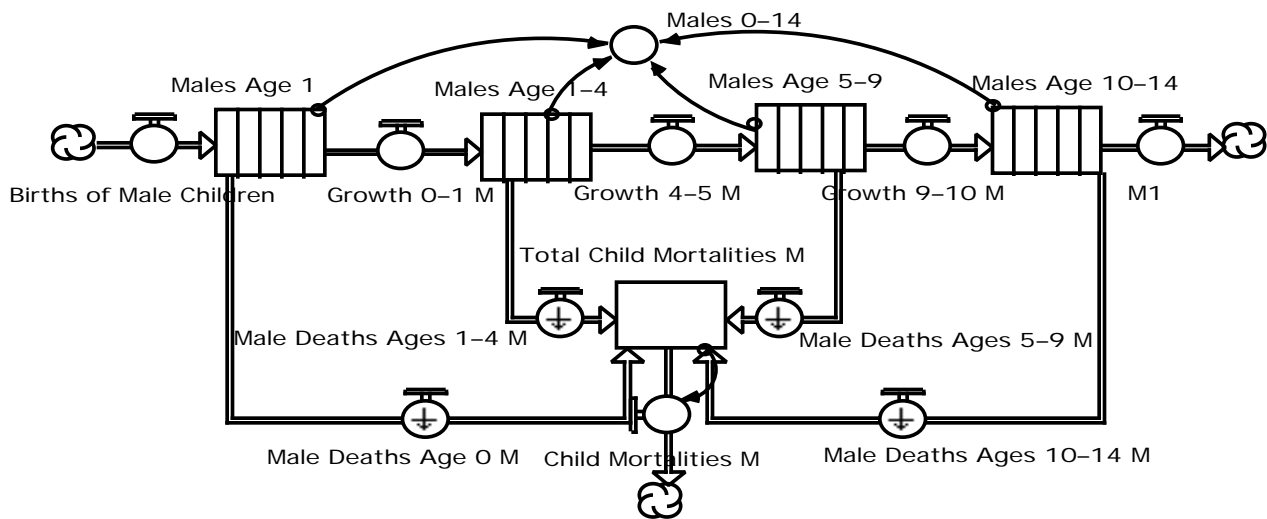

Figure 13: Submodel under the Young Males Segment of the Male Population Model shown in figure 12.

Finally, a graph displaying the results of the simulation from the year 1990 to the year 2090 is included below.



Figure 14: Projection of male, female, and total China population from 1990 to 2090

The design of the three models to study the one-baby per family policy in China, with the explanation for why each of the first two were insufficient, the extensive research, the validation, and the exceptional paper produced marked this effort as probably the best model presented in the first four years of the SyM\*Bowl competition.

The examples in this paper represent a few of the best models students have produced in the past five or six years. Not all students produce models of high quality, but all produce models that increase, significantly, their understanding of the problem they are trying to model.

It is hoped that the examples included in this paper demonstrate that high school students can conceptualize and design models dealing with significant issues. Over three-fourths of the models presented here were developed by

girls. What is not illustrated in this paper, but is even more powerful evidence that the students understand what they have modeled and the results of the models, are the student papers. SyM\*Bowl organizers have, for the past three years, collected the papers for all the competing teams and given a copy to each participating school. In 1999, for the first time, many of the competition models and papers were made available on CD.

We have found that our students are the best spokespersons for systems thinking and dynamic modeling. Listening to the students will convince even the most steadfast skeptic that high school student CAN understand this level of analysis.

<sup>1</sup> SyM\*Bowl was the creation of Dr. Ed Gallaher, research pharmacologist at Oregon Health Sciences University in Portland, Oregon. Dr. Gallaher uses system dynamics modeling in his drug research and when he instructs medical students.

He is an enthusiastic advocate of systems modeling at the high school level.

<sup>2</sup> Dr. George Richardson is a professor of public administration, public policy, and information science, at the Nelson Rockefeller College of Public Affairs and Policy at the State University of New York at Albany.

<sup>3</sup> Dr. Sterman is director of the Sloan School of Management at Massachusetts Institute of Technology and first saw this student model diagram at the International System Dynamics Conference in Cambridge, Massachusetts in 1996.

*Diana Fisher*  
*Franklin High School*  
*5405 SE Woodward St.*  
*Portland, Oregon USA 97206*  
*503-916-5140*  
*dfisher@pps.k12.or.us*  
*dmfisher@jps.net*

*This paper is available from the CLE and the website catalogued as SE2001-03StudentsSDModels.*



# THE NINETEENTH INTERNATIONAL CONFERENCE OF THE SYSTEM DYNAMICS SOCIETY

## July 23-27, 2001

### Emory Conference Center, Atlanta, Georgia, USA

### Hosted by A.T. Kearney, Inc.

The REGISTRATION BROCHURE AND FORM are located on the Conference website: [www.albany.edu/cpr/sds/](http://www.albany.edu/cpr/sds/) Click on "2001 Conference."

**VENUE:** The Emory Conference Center is an attractive Frank Lloyd Wright-style complex. The conference site is a charming, full-service facility that lends itself to close interaction among participants.

**TRAVEL:** For your convenience, the conference is registered with a local travel agency: Uniglobe Accent Travel Services, Atlanta, Georgia USA Phone: (770) 200-7100 or (800) 969-7575, Fax: (770) 200-7101 E-mail: [info@accenttravel.com](mailto:info@accenttravel.com) Website: [www.accenttravel.com](http://www.accenttravel.com)

Other travel information about Delta Air Lines special airline rates; Atlanta Hartsfield International Airport; cost and availability of taxis and shuttles from the airport to the conference center; driving instructions; and traveling around Atlanta is available on the website.

**ON-SITE ACCOMMODATIONS:** The Conference organizers strongly encourage you to stay at the conference center. Our conference will be the only event at the conference center and the hub of all our activity will be there.

Reservations for rooms at the conference center and at the Emory Inn next door should be made directly through the conference center. For room reservations, please call +1 (404) 712-6000 or E-mail reservations to [sales@ecch.emory.edu](mailto:sales@ecch.emory.edu). Room space and rates are being held specifically for our conference until June 8, 2001. After this date, all unused rooms will be released for general sale. Any reservations received after this will be accepted on a space and rate available basis.

**HOTEL AND CONFERENCE REGISTRATION SPACES AT THE CONFERENCE CENTER ARE LIMITED. PLEASE MAKE YOUR RESERVATIONS AND REGISTER EARLY.**

**EARLY AND LATE STAY-OVER** (July 21, 22, 27, 28) can be reserved on a space-available basis only.

**ROOM CANCELLATION POLICY AT EMORY CONFERENCE CENTER:** "Any cancellations or no shows after June 23, 2001 will result in the forfeit of the Complete Meeting Fee." Your room reservations are subject to the Emory Conference Center cancellation policy.

**OFF-SITE ACCOMMODATIONS:** We urge you to stay on-site. Participants staying off-site must purchase a daily guest pass in addition to registration. Off-site participants must complete a special off-site registration form. We are looking into the

possibility of a limited number of student dormitory rooms. For more information, please contact the Society.

For LOCAL INFORMATION OF INTEREST TO TRAVELERS about weather, currency, ATM's, tipping, and visa requirements, please visit the website.

**PROGRAM AND TENTATIVE CONFERENCE SCHEDULE:** The conference will bring together about 400 participants and practitioners interested in system dynamics and systems thinking. The conference organizing committee reserves the right to change the program without notice.

The Social Program includes the Informal Gathering on Monday, the Welcome Reception Cocktail Dinner on Tuesday, the Conference Banquet on Wednesday, and a Southern Cookout with Jazz Band is scheduled for Thursday night.

**Other Events:** A FIRESIDE CHAT WITH JAY W. FORRESTER, sponsored by HVR Consulting, is scheduled for 5 pm on Wednesday. Questions will be collected and Jay will be interviewed. The PhD STUDENT COLLOQUIUM, sponsored in part by South Bank University, is tentatively scheduled to meet on Sunday, July 22. The CONSULTANTS' ROUNDTABLE is scheduled for lunchtime on Tuesday.

Also planned for the conference: The SD CAREER LINK, a job exchange to promote awareness of positions in the field; and the exhibit COURSEWORK IN SYSTEM DYNAMICS, a table displaying brochures about international course offerings.

**PhD SEMINARY SERIES TAPES:** In 1999, Jay W. Forrester conducted eleven, three-hour, doctoral seminars in system dynamics at MIT. Each videotaped session is on a different topic. Session descriptions and details for ordering will be available at the conference.

The CENTER FOR DISEASE CONTROL is located just across the street from the conference center. The CDC is offering our participants and guests a Global Health Odyssey Tour.

**NEW PRIZE FOR BEST STUDENT PAPER** at the International System Dynamics Conference. The Society announces the creation of a new prize to be awarded at the annual international conference, starting this year in Atlanta. The new prize recognizes the growing amount and quality of student work in the field of system dynamics. Please see registration brochure for more information.

The FIRST EVER POOL (BILLIARD) TOURNAMENT will be randomly seeded and single elimination. This friendly competition will be held in the clubroom.

## ONE STUDENT'S POSITIVE FEEDBACK

### Sixth in a series of "What It's Like to Be a Pioneer"

Prepared with the support of the Gordon Stanley Brown Fund by Debra Lyneis

*Jay Forrester has suggested that we could speed the spread of learner-centered-learning and system dynamics in K-12 education by sharing tales of "what it's like to be a pioneer." It might help others who are starting out to know about other teachers' experiences, triumphs and tribulations. This paper presents just one little vignette. If you have other tales to share, please let Deb Lyneis know ([LyneisD@clexchange.org](mailto:LyneisD@clexchange.org))*

Teachers often wonder how they can convince others of the benefits of system dynamics in K-12 education. Perhaps they should let their students do the talking.

One student speaks very clearly in his correspondence with Marti Lynes, his former high school physics teacher who pioneered system dynamics at Algonquin Regional High School in Northboro, Massachusetts:

First of all, congratulations on the [Tandy Technology Scholars] award. You definitely deserve it for your hands-on approach to teaching and the new and exciting curriculum that you bring to the classroom.

When I took my first physics course at Stanford, I found myself up against many students from private and magnet schools who had taken two years of calculus-based physics, the AP exam, and had covered more topics. Yet I found most did not possess as advanced a physics intuition as most Algonquin HS honors students do by the end of the year. While their breadth surpassed mine, they lacked enough real understanding of concepts to be able to use their knowledge on difficult exams. Your class helped me to develop not only a knowledge of physics, but an understanding and indeed an intuition. I didn't realize the full value of this until the first exam in mechanics when I joined 3 other students in a 300+ class in acing the exam. ...I have been able to get straight A's so far in the physics course...

Two years later, this same student wrote to Mrs. Lynes from Germany:

After studying at Stanford's program in Berlin, I now have a six month internship developing a computer model of an airbag for Volkswagen. Trying to create a realistic computer model of an

airbag reminds me of working on STELLA models of water rockets. A bit more complex, but similar principles and challenges. Another fine example of where your class was years ahead of many other high school classes.

These words are powerful testimony on the lasting benefits of system dynamics in education for this fine student. Many other students could also express similar ideas at their own levels and in their own areas of study. Their feedback is valuable and convincing.

*Marti Lynes has carefully presented the system dynamics water rocket lesson for other teachers to try. Her lesson, "Soda Bottle Water Rockets: Build the Rockets and the Models," prepared with the support of the Gordon Stanley Brown Fund, 1999, is available from the Creative Learning Exchange and free on-line at <http://sysdyn.mit.edu/cle/>. Look for SC1999-03SodaBottleWaterRkt under Science Materials.]*

*This article is also available from the CLE and the Web site, catalogued as SE1999-09Pioneer4-1Student.*

## NINETEENTH INTERNATIONAL CONFERENCE OF THE SYSTEM DYNAMICS SOCIETY

### CONFERENCE CONTACTS:

Conference Chair: Dr. Nathan B. Forrester, Principal, A.T. Kearney, Inc. E-mail: [nathan.forrester@atkearney.com](mailto:nathan.forrester@atkearney.com)

Program Chair: Dr. James H. Hines, Senior Lecturer  
Massachusetts Institute of Technology E-mail: [jhines@mit.edu](mailto:jhines@mit.edu)

Conference Manager: Roberta L. Spencer, System Dynamics Society E-mail: [system.dynamics@albany.edu](mailto:system.dynamics@albany.edu)

Vice-Chair, Program: Vedat G. Diker, University at Albany  
E-mail: [vd7606@csc.albany.edu](mailto:vd7606@csc.albany.edu)

Workshop Coordinator: Hazhir Rahmandad

Vice-Chairs, Topics: Ed Anderson, Farzana Mohamed, Mila Getmansky, Paulo Goncalves, Major Marc A. Lee, Nan Lux, Brad Morrison, Nelson Repenning

Coursework Coordinator: Patricia Quinn

SYSTEM DYNAMICS SOCIETY  
Milne 300, Rockefeller College  
135 Western Avenue  
State University of New York at Albany  
Albany, NY, 12222, U.S.A.  
phone (518) 442-3865  
fax (518) 442-3398  
[system.dynamics@albany.edu](mailto:system.dynamics@albany.edu)  
<http://www.albany.edu/cpr/sds/>

## GORDON STANLEY BROWN FUND

To support preparation for distribution of materials for using system dynamics in K-12 education

**T**he Gordon Stanley Brown Fund has been established to promote system dynamics and an understanding of dynamic behavior in feedback systems in kindergarten through 12th grade schools. The Fund will focus on making teaching experiences available to others. Small and medium sized proposals are encouraged.

The Gordon Brown Fund can support teachers for:

- Released time or summer time used to put into transmittable and usable form materials and methods that have already been used in schools and that could be of help to others,
- Communicating experiences that did not meet expectations so that others can be forewarned.

Work supported by the Fund is to be available for distribution through the Creative Learning Exchange and any other channels that the author arranges.

The Fund honors Gordon Brown, who pioneered the theory and practice of feedback dynamics and engineering control systems at MIT in the 1940s. Brown went on to be head of the Electrical Engineering Department and Dean of Engineering at MIT. During retirement, he devoted energy and skillful leadership to bringing system dynamics into the Catalina Foothills school system in Tucson, Arizona.

Address applications, with an outline of the proposed project, to:  
Lees N. Stuntz, Creative Learning Exchange, 1 Keefe Road, Acton, MA 01720

## New Materials now Available from the CLE and on-line at [www.clexchange.org](http://www.clexchange.org)

**SE2000-12BringSDToSchool    Bringing System Dynamics to a School Near You: Suggestions for Introducing and Sustaining System Dynamics in K-12 Education.** Debra A. Lyneis

Presented at the 2000 International System Dynamics Society Conference in Bergen, Norway, this paper explains how system dynamics is introduced and sustained in schools, outlining some of the many generous contributions that have made the early growth of K-12 system dynamics possible, and giving readers many resources and practical suggestions for how they can participate, too. [Systems Education, Implementation, K-Adult] (\$2.00)

**SE2001-03RubricsForSDTools    Rubrics for Understanding: Using System Dynamics Tools.** DynamiQue<sup>ST</sup> 2000 Committee

Updated for 2001. Originally developed by the DynamiQUE<sup>ST</sup> 2000 Committee, these newly updated rubrics were created to be used as a complete package to help delineate standards for the use of system dynamics in the classroom. [Systems Education, Cross Curricular, System Dynamics, Behavior over Time Graphs, Causal Loops, Dynamic Modeling, K-Adult] (50¢)

**SE2001-03StudentsSDModels    System Dynamics Models Created by High School Students.** Diana M. Fisher

Presented at the 2000 International System Dynamics Society Conference in Bergen, Norway, this paper presents examples of models with serious mistakes made in the early years of modeling classes in Portland, OR, and a larger set of good models that are more recent. Viewing the mistakes of others is often a helpful way to learn. The examples of the good models demonstrate the quality of work of which students are capable. [Systems Education, Cross Curricular, System Dynamics, Behavior over Time Graphs, Dynamic Modeling, K-Adult] (\$1.00)

## Expositions for Student Work in System Dynamics *continued from page 1*

Students may enter original work or their application of other work (CLE, CC-STADUS, etc.) This might include a unit, a lesson, or an application of one or more of the systems tools. Rubrics (available in the DynamiQUEST 2001 section of the CLE website—<http://cleexchange.org>) will be used by coaches to provide feedback related to students use of systems tools and development of systems understanding. The objective is to aim for the standards that apply to the work submitted for DynamiQUEST 2001, whether it is a BOTG or an extensive project with a working model. Remember, the philosophy of DynamiQUEST 2001 is to improve student learning by honoring the work of students as they learn the tools and method of SD/ST. Collaborative projects are encouraged, but individual projects are welcome too.

### What will happen?

- A reviewed poster session where students stand by their work and respond to questions from coaches and visitors
- Students receive feedback from coaches experienced in SD/ST
- An afternoon session where student teams work spontaneously to solve problems using SD/ST tools and present their solutions to the larger group
- Lunch and Snacks provided. *For those groups coming from far away, overnight stays in a nearby motel or with local families will be coordinated. Call (978-287-0070) or e-mail ([stuntzln@cleexchange.org](mailto:stuntzln@cleexchange.org)) Lees Stuntz, Creative Learning Exchange.*

### How students will submit work:

- Write a short proposal for your project (due May 1<sup>st</sup>). See “Guidelines for Written Proposals,” available on the website ([cleexchange.org/cle\\_dq.html](http://cleexchange.org/cle_dq.html))

- Prepare your SD/ST project as a poster that can be displayed on a 4’ X 4’ tabletop. (You may also include a laptop/desktop computer for display; NOTE: computers will *not* be provided for the poster session.) Bring the poster with you. The poster should include:
  1. Title, school name, and student name(s)
  2. Diagrams, graphs, and/or tables of interesting behaviors
  3. Text describing important points, conclusions and “better questions”
- Write a brief summary (or alternative) of your project (1–3 pages, fewer for younger students) as outlined in “Guidelines for Project Summaries,” which is available on the website. The written summary (or alternative) is due May 11<sup>th</sup>.
- All questions and concerns for clarification should be e-mailed to Lees Stuntz ([stuntzln@cleexchange.org](mailto:stuntzln@cleexchange.org))

### Key deadlines:

- Application due: April 25<sup>th</sup>
- Written summary due: May 1<sup>st</sup>
- DynamiQUEST 2001: May 11<sup>th</sup>

**For more information, go to the DynamiQUEST page at the CLE website ([http://cleexchange.org/cle\\_dq.html](http://cleexchange.org/cle_dq.html))**

### SyM\*Bowl

The sixth annual SyM\*Bowl is being held May 2 at OMSI (Oregon Museum of Science and Industry) in the Sky Theater Auditorium, welcoming over 150 students in middle and high school from around the Pacific Northwest. Honored guests and mentors will consult with students and teachers as this event turns its attention to learning and communicating.

And so, SyM\*Bowl Foundation launches a revitalized event that focuses

on what students have learned, and what they can share with each other and their community.

### Who is Invited?

- all middle school and high school students with a systems idea
- teachers and administrators of system dynamics program schools
- local citizen champions of school change

### What Will SyM\*Bowl VI Look Like?

- Say “Goodbye” to competition and “Hello” to Chautauqua—a celebration of the flowering of system dynamics in K-12 schools!
- SyM\*Bowl VI will take on a subtle new look: morning poster sessions, talks on good modeling, demonstrations of systems methods and games, afternoon conference style presentations by students and/or student groups, finishing with kudos, awards, recognitions, and a rousing send off
- Lunches, breaks, time to chat with other young people who work in system dynamics
- Great conversations with national and international system dynamicists

### What Do We Have To Do?

- Inspire students to participate!
- Work with students as they construct models.
- Assist students in writing abstracts and papers for SyM\*Bowl VI.
- Receive information from SyM\*Bowl Foundation and pass it on to students.

**For more information look on the CLE website (<http://cleexchange.org>) or e-mail Tim Joy at [tjoy@jps.net](mailto:tjoy@jps.net).**



## INTERDISCIPLINARY, NATURALLY

*continued from page 1*

### Newsletter Subscription Information

**T**he Creative Learning Exchange Newsletter is available in three different formats:

- On the Web page at [www.clexchange.org](http://www.clexchange.org)
- As an attached file to an e-mail
- In paper via US mail (\$15.00 outside the USA)

Since we vastly prefer electronic distribution to paper because it so much less expensive, please e-mail us at any time when you would like to have an electronic subscription.

<milleras@clexchange.org>

As it happened, Rob's advanced math class was working on curve fitting at the time; students were determining graphs based on data points using various techniques. Meanwhile, in Jim's class the students were conducting a physics of motion experiment rolling cars down ramps and measuring the distances they traveled down the hall. After the experiments were completed, Jim asked his students to graph their results in their lab teams. Jim observed that some students were using advanced graphing techniques and successfully explaining them to their teammates. Surprised, he asked them where they had learned to do that. "Oh, this stuff is easy," they said. "We are learning this in math. See how perfectly it works for this experiment."

Jim couldn't believe it! He practically bounded down the hall to Rob's classroom to show him the connection that the students had made on their own. On the spot, the two teachers decided to graph the physics results in math class and then build a system dynamics model to explain the observed behavior. In science, meanwhile, they would use the model to understand and

extend the experiment by manipulating the variables.

This was Carlisle's first model built to serve a real purpose in the curriculum, and both veteran teachers felt that this had been their first genuinely interdisciplinary experience. Surprisingly, the modeling added new breadth and depth to the original lessons—students asked much better questions. Building this first model was difficult, but the teachers worked together and sought help from others. They also decided to continue on with system dynamics. The rest is history.

*[Note: The science lesson and model are available from the Creative Learning Exchange and on-line at <http://www.clexchange.org> catalogued as CC1997-01LetItRollRampModel, under Cross-Curricular Materials. Look for "Let It Roll" by Rob Quaden, James Trierweiler, and Debra Lyneis, prepared with the support of the Gordon Stanley Brown Fund, 1996.] This article is also available from the CLE and the Web site, catalogued as SE2000-10Pioneer7-Naturally.*

### INTERESTED IN INVESTING?

**I**f you would like to invest in our effort here at *The Creative Learning Exchange*, your contribution would be appreciated. You may donate any amount you wish; perhaps \$50.00 is a reasonable amount for a year. All contributions are tax-deductible.

Enclosed is \_\_\_\_\_ to *The Creative Learning Exchange* to help invest in the future of K-12 systems education.

Name \_\_\_\_\_

Address \_\_\_\_\_

e-mail \_\_\_\_\_

**Thank you!**

***The Creative Learning Exchange, 1 Keefe Road, Acton, MA 01720***

***The Creative Learning Exchange***  
**1 Keefe Road**  
**Acton, MA 01720**  
**Phone 978-287-0070**  
**Fax 978-287-0080**  
**[www.clexchange.org](http://www.clexchange.org)**

#### **Trustees**

John R. Bemis, Founder  
 Jay W. Forrester  
 George P. Richardson  
 Stephen C. Stuntz

#### **Executive Director**

Lees N. Stuntz  
[stuntzln@clexchange.org](mailto:stuntzln@clexchange.org)

*The Creative Learning Exchange* is a trust devoted to encouraging exchanges to help people to learn through discovery. It is a non-profit educational institution and all contributions to it are tax deductible.